

# PROJECT MANUAL

FOR

## **Hoose Court**

705 | 711 W. Wayne Street  
South Bend, Indiana

February 26, 2024

### **BID PACKAGES 1 - 24**

Prepared For:



**South Bend**  
Heritage

Prepared by:

South Bend Heritage  
Construction Management  
Team



711



705

Bids Due:  
March 29, 2024

**TABLE OF CONTENTS**

	<u>Page(s)</u>
<u>COVER PAGE</u> .....	1 and 1
<u>TABLE OF CONTENTS</u> .....	2 and 2
<u>INVITATION TO BID</u> .....	3 and 4
<u>PROCUREMENT SCOPE</u> .....	5 thru 9
 <u>SPECIFICATIONS</u>	
A. Division 0 - Bidding and Contract Requirements .....	10 thru 11
B. Division 1 - General .....	12 thru 16
C. Division 2 - Existing Conditions (Not Applicable)	
D. Division 3 - Concrete .....	16 thru 18
E. Division 4 - Masonry (Not Applicable)	
F. Division 5 - Metals .....	18 thru 18
G. Division 6 - Wood and Plastics .....	18 thru 24
H. Division 7 - Thermal and Moisture Protection .....	24 thru 26
I. Division 8 - Openings .....	26 thru 27
J. Division 9 - Finishes .....	27 thru 29
K. Division 10 - Specialties .....	29 thru 29
L. Division 11 - Equipment .....	29 thru 29
M. Division 12 - Furnishings .....	29 thru 30
N. Division 21 - Fire Suppression (Not Applicable)	
O. Division 22 - Plumbing .....	30 thru 32
P. Division 23 - HVAC .....	32 thru 34
Q. Division 26 - Electrical .....	34 thru 37
R. Division 27 - Communication (Not Applicable)	
S. Division 31 - Earthwork .....	37 thru 39
T. Division 32 - Exterior Improvements .....	39 thru 39
U. Division 33 - Utilities .....	39 thru 40

INVITATION TO BID

**Notice is hereby given that South Bend Heritage will receive sealed bids for Bid Packages for the construction of a new two side-by-side & stacked duplexes, four units affordable housing, located in South Bend, Indiana.**

FOR THE PROJECT: **Hoose Court  
703 | 711 W. Wayne  
Street South Bend, IN  
46615**

**BID PACKAGES 1 – 24**

BY THE OWNER: SOUTH BEND HERITAGE  
803 Lincoln Way West  
South Bend, IN 46616

BID OPENING: **2:00 p.m. EST on Friday, March 29, 2024**

Bids received after that time will be returned  
unopened. The sealed Bids will be privately opened.

DOCUMENT AVAILABILITY: **Monday, March 4, 2024**

CONTRACT TIME: Shall not exceed 270 calendar days from Owner  
Notice to Proceed.

All work for the complete construction of the project will be under multiple prime contracts with the Construction Manager/General Contractor (CM/GC), based on bids received and on combinations awarded. The Construction Manager will manage the construction of the project.

The Owner reserves the right to accept or reject any bid (or combination of bids) and to waive any irregularities in bidding. No bidder may withdraw his bid for a period of sixty (60) calendar days after the date set for bid opening.

OFFICES OF THE CONSTRUCTION MANAGER/GENERAL CONTRACTOR (CM/GC):

SOUTH BEND HERITAGE  
803 Lincoln Way West  
South Bend, IN 46616

The Contract Documents are on file and available for public inspection during regular working hours at the offices of the CM/GC, South Bend Heritage, 803 Lincoln Way West, South Bend, IN 46616. Contact: Safa Saddawi Telephone (574) 274-5678. Or you can access the documents online at <https://sbheritage.org/resources/contractors>. Then go to Current Projects

Additionally, the **Contract Documents will be available for inspection or purchase at ARC Document Solutions**

**(ARC), located at 1303 Northside Blvd., South Bend, IN 46615, <http://www.e-arc.com> (574) 287-2944, toll free (800) 783-7231.** There will be a non- refundable charge of the cost for reproduction as set by ARC for every set of documents for all bidders.

**Bidders must direct all questions in writing during the bidding period to South Bend Heritage, Safa Saddawi; [safas@sbheritage.org](mailto:safas@sbheritage.org)**

The successful bidders will submit their Federal Identification Number to the CM/GC, prior to signing the contract. In the absence of an F.I.N., they must submit their Social Security Number.

An out-of-state contractor will be obligated to show proof that they are registered with the Indiana Secretary of State to conduct business in the State of Indiana.

**Prevailing Wage Rates will NOT be applicable to this project.**

END OF SECTION

## PROCUREMENT SCOPE

### A. GENERAL

#### 1. RELATED DOCUMENTS

- a. Project includes total construction of a 4-unit 2- duplexes, all in accordance with plans and specifications prepared by South Bend Heritage Construction Team dated 2/26/2024. Refer to Specifications Section B.1. Summary of Work, b. Project Description.
- b. **Invitation to Bid.** The requirements are set forth in Division 1. GENERAL REQUIREMENTS shall apply to all contractors and/or subcontractors.

#### 2. SCOPE

- a. Each contractor is responsible for familiarizing themselves with the entire contents of the Construction Documents and their respective bid packages. Specifications and Drawings listed under each bid package are for reference and may not include every aspect of the bid package.

#### 3. WORK COVERED BY CONTRACT DOCUMENTS

##### a. GENERAL

- 1) All work for the complete construction of this project will be under multiple prime contracts with the South Bend Heritage Construction Manager/GC.
- 2) Each contractor is responsible for their own cutting and patching where necessary.

##### b. BID PACKAGE 1 – EARTHWORK

- 1) Installation of erosion control measures.
- 2) Site preparation work.
- 3) Earthwork including site excavation, special excavations, compaction, rough grading, and finish grading.
- 4) Placement and compaction of all engineered fill.
- 5) Placement, finish grade and compaction of all subbase materials for walks and exterior slabs.
- 6) Installation of sanitary sewer.

##### c. BID PACKAGE 2 – BUILDING CONCRETE

- 1) Construction of concrete footings and foundation walls.
- 2) Application of damp-proofing and insulation.
- 3) Construction of concrete building slab, including front and rear porches and stoops.
- 4) Placement, finish grade and compaction of floor slab course, including radon abatement mat around the perimeter of the building.
- 5) Excavation, backfill and subgrade compaction for building footprints.
- 6) Foundation wall sleeves for utilities pass-thru.

##### d. BID PACKAGE 3 – TERMITE CONTROL (BY OWNER)

- 1) Termite control for building foundation and under slab areas

##### e. BID PACKAGE 4 – SITE CONCRETE

- 1) Construction of all concrete walks, curbs, and exterior slabs.
- 2) Construction of exterior porch steps.

- f. **BID PACKAGE 5 – METALS**
- 1) Provide all miscellaneous metals and stair railings.
  - 2) Installation by others.
- g. **BID PACKAGE 6 – GENERAL TRADES 1: FRAMING/ ROUGH CARPENTRY**
- 1) Construction of wood framed walls, floors, and roof trusses.
  - 2) Construction of exterior walls sheathing and building wrap.
  - 3) Construction of wood framed stairs.
  - 4) Installation of sill seals at exterior walls.
  - 5) Installation of all exterior wall doors, windows and perimeter flashing tape.
  - 6) Installation of temporary enclosures and protection.
  - 7) Provide and install all exterior joint sealants.
  - 8) Provide and install all wood blocking, including as needed for planned firestopping assemblies.
  - 9) Construction of all wood decking.
  - 10) Provide and install flooring underlayment.
  - 11) Construct project construction sign. Signboard to be provided by Owner.
  - 12) Construction of plywood insulation protection at attic access openings.
  - 13) Install exterior doors.
- h. **BID PACKAGE 7 – GENERAL TRADES II: FINISH CARPENTRY AND ARCHITECTURAL WOODWORK**
- 1) Provide all finish carpentry.
  - 2) Installation of all interior doors/frames, access doors, attic access doors, door hardware.
  - 3) Installation of casework and countertops.
  - 4) Installation of all toilet room, bathroom accessories.
  - 5) Provide and install joint sealants.
  - 6) Installation of Specialties, mailboxes, unit address numbers.
  - 7) Installation of interior windows' sills.
  - 8) Installation of stair railings.
  - 9) Installation of window blinds.
  - 10) Installation of exterior porch railing.
  - 11) Install or set in place all appliances, including heat shield at each range.
  - 12) Install closet shelving.
- i. **BID PACKAGE 8 – INSULATION**
- 1) Provide and install all building insulation including perimeter walls, interior walls, ceilings, and attic.
  - 2) Provide and install spray applied insulation.
- j. **BID PACKAGE 9 – ROOFING**
- 1) Provide and install fiberglass-based asphalt shingle roof.
  - 2) Provide and install roof flashing, roof/wall flashing, and pre-finished trim.
  - 3) Provide and install all roof accessories.
- k. **BID PACKAGE 10 – GUTTERS AND DOWNSPOUTS**
- 1) Provide and install all gutters and downspouts.
  - 2) Provide and install splash blocks at downspouts.
- l. **BID PACKAGE 11 – SIDING AND TRIM**
- 1) Provide and install vinyl siding, including vinyl accessories and LP trims and fiberglass columns.
  - 2) Provide and install all preformed soffit systems and fascias.
  - 3) Construction of exterior plywood mounting blocks at electrical meters and plywood phone/data panels.
- m. **BID PACKAGE 12 – WINDOWS (OWNER)**

- 1) Provide all window units.
  - 2) Installation by others.
- n. **BID PACKAGE 13 – DOORS AND HARDWARE (OWNER)**
- 1) Provide all exterior doors/frames.
  - 2) Provide all wood doors/frames.
  - 3) Provide all access panels and attic access doors.
  - 4) Provide all door hardware.
  - 5) Installation by others.
- o. **BID PACKAGE 14 – GYPSUM DRYWALL**
- 1) Provide and install gypsum wallboard systems.
- p. **BID PACKAGE 15 – RESILIENT FLOORING**
- 1) Provide and install all resilient flooring, wall base and trim accessories.
- q. **BID PACKAGE 16 – CARPET**
- 1) Provide and install all carpet systems including wall base and trim accessories.
- r. **BID PACKAGE 17 – PAINTING**
- 1) Provide and install all paint systems.
- s. **BID PACKAGE 18 – SPECIALTIES (OWNER)**
- 1) Provide postal specialties.
  - 2) Provide window blinds.
  - 3) Installation by others (See Bid Package 9 - General Trades II - Finish Carpentry).
- t. **BID PACKAGE 19 – RESIDENTIAL APPLIANCES (OWNER)**
- 1) Provide all kitchen appliances for Units.
  - 2) Provide all Laundry Room appliances.
  - 3) Installation by others.
- u. **BID PACKAGE 20 – CASEWORK (OWNER)**
- 1) Provide all pre-manufactured casework.
  - 2) Installation by others.
- v. **BID PACKAGE 21 – PLUMBING**
- 1) Provide and install all plumbing systems from stub 5 feet outside of building, including domestic water, sanitary, and sewer.
  - 2) Install residential appliances with water connections.
  - 3) Provide and install passive radon piping system from below slab to above the roof.
- w. **BID PACKAGE 22 – MECHANICAL**
- 1) Provide and install all heating, ventilating and air conditioning systems.
  - 2) Fabricate and install ductwork.
  - 3) Provide and install firestopping.
  - 4) Install Gas piping system to furnace.
- x. **BID PACKAGE 23 – ELECTRICAL**
- 1) Provide and install all electrical systems for building and site.
  - 2) Provide and install firestopping.
  - 3) Install appliances with electrical connection (cord with cord-connected appliances).

- y. **BID PACKAGE 24 – LANDSCAPING**
  - 1) Provide and install plant materials.
  - 2) Provide and install lawns includes edging and seeding.

4. PRIME CONTRACTS

- a) The multiple prime contracts are defined by Bid Packages which designate one or more various disciplines of work. These Bid Packages are being packaged to maintain job scheduling. Due to this fast-track method, time is of the essence in performance of this work.

A construction progress schedule, which defines milestone progress for this project, will be issued with each Contract. This schedule will be preliminary and is meant to define the project goals. A more detailed schedule will be developed after contracts are awarded.

- a) The Bid Package Subdivisions (BPS) being considered under this Bid Package are as follows:

a)	<u>BPS</u>	<u>Description</u>
	1	EATHWORK
	2	BUILDING CONCRETE
	3	TERMITE CONTROL
	4	SITE CONCRETE
	5	METALS
	6	GENERAL TRADES I – FRAMING/ROUGH CARPENTRY
	7	GENERAL TRADES II – FINISH CARPENTRY AND ARCHITECTURAL
	8	INSULATION
	9	ROOFING
	10	GUTTERS AND DOWNSPOUTS
	11	VINYL AND POLYMER SIDING
	12	WINDOWS
	13	DOORS AND HARDWARE
	14	GYPNUM DRYWALL
	15	RESILIENT FLOORING
	16	CARPET
	17	PAINTING
	18	SPECIALTIES
	19	RESIDENTIAL APPLIANCES
	20	CASEWORK
	21	PLUMBING
	22	MECHANICAL
	23	ELECTRICAL
	24	LANDSCAPING

- b) Future Bid Packages will be added under subsequent phases of construction documents, which will, in total, define the overall scope of this project.

5. OWNER REQUIREMENTS AND USE OF PREMISES

- a. It is the intention of the Owner to award contracts to the successful Bid Package Sub-Division Contractors who submit the lowest and/or best bid. Any bidder, at his/her option may submit a combined bid made from any combination of individual bid package sub- divisions. A separate bid must be submitted for each bid package sub-division and applicable alternates in addition to the combined bid. Combined bids



will not be considered unless the bidder also submits separate bids on each bid package sub-division and alternates contained in the combined bid. Voluntary alternates will be considered provided the bidder first submits a bid based on specified work.

- b. Abusive language, music radios, actions or disrespectful behavior by any workers directed to Construction Manager/GC's employees, visitors, or others while working on the project grounds is subject to immediate removal and dismissal.
- c. Designated smoking areas, parking areas, and construction trailer staging areas will be as directed by the Construction Manager/GC. No parking or loitering will be permitted on access roads or mobilization areas. Fire lanes shall be kept clear at all times to maintain access to the completed buildings and fire department connections.
- e. No materials may be stored within the building. Contractors shall be responsible for scheduling on time delivery of their materials or providing their own storage trailers on site, located as directed by the Construction Manager/GC.

6. LICENSE REQUIREMENTS

- a. All contractors shall be licensed as required by Local and State agencies. Contractors shall verify these requirements with the respective governing agencies.

B. PRODUCTS (Not used)

C. BID PACKAGE SUBDIVISION DESCRIPTION

- 1) All products listed will be furnished and installed unless otherwise noted. All Contractors shall be responsible for layout for their scope of work.
- 2) Refer to Drawings and Specifications referenced the Related Documents section above.

END OF SECTION

# SPECIFICATIONS

February 26, 2024

## A. DIVISION 0 - BIDDING AND CONTRACT REQUIREMENTS

1. This Specification originally dated February 29, 2024, supersedes and replaces all prior specifications for this project.
2. Bids will be due on **Friday, March 29, 2024**, at the SBH offices by 2:00 p.m. (Received via mail, faxed, emailed, or dropped off by this time.) SBH offices are located at 803 Lincoln Way West, South Bend, IN 46616. Bids are sent to the attention of Safa Saddawi at 574.289.1066.
3. Throughout this document, South Bend Heritage Foundation, Hosse Court, SBH and SBHF shall all be interpreted as "Owner".
4. Bids not utilizing the attached Bid Form will not be accepted. Additional materials may be submitted. Voluntary alternates submitted in addition to the primary bid documents will be considered. One bid form per bid package.
5. Bidder References: Provide names and contact information for three prior clients in which your company demonstrated an ability to deliver a project under a demanding schedule or otherwise met your client's schedule expectations. One criterion for determining bidder responsiveness will be a demonstrated ability to deliver projects on schedule.
6. Bidder Registration: All bidders must notify SBH of their intention to bid by Wednesday, October 11, 2023. Project notices and addenda notices will be emailed to registered bidders only. Contractors who received an RFP invitation to bid emailed from SBH are considered pre-registered.
7. Full and complete Contractor markup on any positive value change orders to be disclosed on the Bid Form.
8. Bid the work according to the RFP documents. If you or your subs have questions about elements of the work, please contact SBH. If information is lacking, SBH will issue new guidelines (Addendums) to all Bidders. References to work by subcontractor shall refer to all divisions of work unless specifically assigned to a particular subcontractor by the bid package description contained in the RFP.
9. Voluntary Alternates:
  - a. Bidders may submit voluntary alternates. Voluntary alternates will only be considered if the bidder has first provided a bid for the work as specified. List voluntary alternates on a separate form or additional copy of the bid form. Number and clearly describe the scope of each voluntary alternate.
  - b. SBH will also consider a voluntary alternate in which two or more separate bid packages are linked for a combined bid amount different than the sum of the separate bid amounts.
10. Approved Equal (Substitutions): No substitutions of specified products are permitted without written approval from SBH.
11. Contract between General Contractor and Subcontractor: The successful bidders will be expected to execute AIA Document A401, latest edition, Standard Form of Agreement Between Contractor and Subcontractor or an equivalent SBH agreement. Review copies of this agreement are available from SBH.

12. Applications for Payment:
  - a. Draw requests will be made from the Contractor to the Owner at no less than 30-day intervals utilizing AIA G702 and G703 forms. Payment will be made only for work in place at time of the application for payment. Materials purchased and stored may be billed if covered against loss by a certificate of insurance acceptable to SBH.
  - b. Monthly applications are due to SBHF on the 25th of each month. Payment may be expected from SBH in not less than 30 days or more than 45 days.
13. Notice to Proceed: No billable work or commitments of any sort are to begin on the project until after the Contractor has received a written notice to proceed from the Owner. Notice to proceed will be issued to all contractors at the same time at least one (1) week prior to the start of construction.
14. Schedule for Construction: See Division 1.
15. Retainage: Contract will be executed with 5% retainage on each subcontractor draw. Retainage will be released upon Substantial Completion of the Contract minus an amount ascribed to specific punch list items until those items are completed and as otherwise described in AIA A201.
16. Prevailing Wage and Certified Payrolls: This project does not fall under prevailing wage guidelines..
17. Insurance: Certificates of insurance will be required prior to start of the Work. Refer to attached minimum limits of liability. South Bend Heritage Foundation, Inc. shall be named as additional insured under the Contractors' Comprehensive General Liability Policy.
18. MBE and WBE:
  - a. South Bend Heritage is committed to minority and women's business enterprise participation in this project.
  - b. As a requirement for bidding on this project, all bidders shall provide written documentation evidencing the bidder's good faith efforts to further South Bend Heritage Foundation's desire to facilitate local worker and MBE/WBE participation in this project. Such documentation shall include a listing of all MBE/WBE's contacted including: (1) the name and address of the MBE/WBE; (2) the type of contact made (i.e. telephone, written solicitation, etc.); (3) the date of the contact; (4) the nature or type of services or goods requested; and (5) the result of the contact.
  - c. Responsive bidders shall include this written evidence of their good faith efforts including copies of outreach and copies of email exchanges inviting and receiving quotes or other responses from MBE/WBE firms or other documentation of efforts to encourage and secure competitive quotes from MBE/WBE and local businesses to be included in the benefits of building this project. Written documentation of letters of introduction, invitations to forging majority/minority strategic alliances for capacity building including but not limited to mentoring, extensions of assistance on payroll, insurance, bonding, line of credit, technical skills or business skills will be accepted as further evidence of good faith effort.
  - d. All bidders are actively encouraged to reach out to the MBE/WBE firms in St. Joseph County and make real good faith efforts to forge constructive and lasting business partnerships.
19. Copies of the winning bid forms will be available from the Owner after the Contract is awarded and construction has commenced.

B. DIVISION 1 - GENERAL

1. Summary of the Work:

- a. Refer to the individual bid package descriptions in a separate document. These bid packages are not specifications. They merely divide the work into biddable portions and refer to the Specifications. The scope of work described in bid package does not limit the Contractors' responsibility to understand the entire project and the required coordination of their work with other trades.

- b. Project Description: Project consists of complete construction of residential structures: (2) two duplexes, side-by-side duplex, option "c" and Stacked duplex, option "c". Four (4) total dwelling units in South Bend, Indiana. Project includes site development of curbs and walks, signage, grading, and landscaping, all as shown on the Project Drawings provided by the City of South Bend (Model Building Type, option "c")

2. Printed Documents: To order prints of the Drawings (full or half size) and associated RFP documents, contact ARC (previously South Bend Drafting Supply), 1303 Northside Blvd., South Bend IN, 574-287-2944. Interested bidders are responsible for purchasing and picking up bid packages from ARC.

3. Coordination and Precedence of the Contract Documents: The documents included in the Contract are intended to be complementary and to describe a complete work. In case of a difference between Drawings and Specifications, the Specifications shall govern.

4. Means and Methods: The Drawings are meant to indicate the general scope of the bid package as related to the site plan, floor/roof plans, and elevations, and are not intended to be fully detailed construction documents. Contractor is responsible for all construction means and methods. This wood frame residential structure and all parts thereof, shall be designed and constructed in strict compliance with the Indiana Residential Code 2018 (IRC) to safely support all loads without exceeding the allowable stresses for materials of construction in structural members and connections. This includes concrete foundation walls/footings, floor, wall and roof framing, beams, lintels, and wind/lateral loading. The building structural design shown on the Drawings is a guide for Bid Package 6 bidders. Variations from the design shown shall be approved by the Owner and Architect. The site office/community room and the six-plex buildings shall comply with the Indiana Building Code 2014 (IBC 2012 referenced).

5. South Bend Heritage reserves the right to reject any or all bids, and to waive any irregularities in bidding and to make an award in the best interest of the South Bend Heritage Foundation and the City of South Bend.

6. Minor Changes: The subcontractor will advise the Owner of minor changes in the Work not involving an adjustment to Contract Sum/Price or Contract Time.

7. Requests for Information (RFI): The subcontractor may submit a request for information to SBH to seek clarifications or resolution to questions that arise during the course of the Work that are not covered in the Construction Documents. The SBH will respond within five (5) days.

8. Architects Supplemental Instructions (ASI): The Architect or SBH may issue supplemental instructions which include a detailed description of a clarification or proposed change with supplementary or revised Drawings and Specifications. If the ASI results in a change to the Contract

9. Sum and/or Contract Time, the Contractor will prepare and submit an estimate within ten (10) days.
10. Potential Change Orders (PCO) Change Orders (CO): The subcontractor may propose a change by submitting a PCO request for change to the SBH, describing the proposed change and its full effect on the Work, with a statement describing the reason for the change, and the effect on the Contract Sum and Contract Time with full documentation.
11. Permits:
  - a. The *Utility Verification Form* from the SB BOPW will be coordinated and paid for by the Owner.
  - b. The occupancy permit (if required); plumbing permit fee shall be paid by the subcontractor; water main taps and stop valves to be installed by the City of South Bend.
  - c. The sewer inspection fee, if required, to be paid by the subcontractor. Sewer lateral shall be installed to each building site by the City of South Bend.
  - d. The sewer excavation fee (for excavation within the property line) to be paid by contractor installing the lateral only if required by the BOPW. It is the Contractor's responsibility to determine if this fee applies for the base bid condition.
12. Schedule: Construction is expected to begin approximately Fall 2023. Notice to Proceed will be issued to all contractors at least one (1) week prior to start date. Subcontractors may not begin work until satisfaction of all pre-construction requirements. The Schedule is of the essence for this project. Refer to the schedules for each bid package as outlined in the bid package descriptions. Schedules are provided for bidding and general coordination purposes. Contractors will be notified by SBH if adjustments to the schedule are made.
13. Adverse Weather: N/A.
14. Bidder References: Provide names and contact information for three (3) prior clients in which your company demonstrated an ability to deliver a project under a demanding schedule or otherwise met your client's schedule expectations. One criterion for determining bidder responsiveness will be a demonstrated ability to deliver projects on schedule.
15. Meetings and Coordination:
  - a. Standard Pre-Construction Meeting: Date and agenda to be determined.
  - b. The following shall be provided by each subcontractor in advance of the meeting:
    - C Draft schedule of values on AIA G702/G703.
  - c. SBH is responsible for the coordination of schedules, submittals, and the Work to assure efficient and orderly sequence of installation of interdependent construction elements.
16. Energy Code Compliance: This project will meet the energy code using the performance path.
17. Submittals and/or Shop Drawings:
  - a. Submittals from Contractors to Architect or Owner and SBH are required for the following:
    - C Truss and framing package showing primary structural calculations and loading.
    - C Panelized wall system if used and other primary structural elements.

- Identify portions of walls to be bracing wall panels or shear walls.
  - C Windows - fabricator submittal / shop drawings / energy standard compliance.
  - C Exterior doors - manufacturer submittal including assembly U-values and glazed door SHGC values.
  - C Interior doors - manufacturer submittal.
- 
- C Door hardware - manufacturer submittal.
  - C Gypsum wallboard and gypsum liner panels.
  - C Sound board.
  - C Cabinetry layout - vendor drawing based on field verified dimensions.
- 
- C All exterior finish materials and colors, including colored flashing - material sample with color applied.
  - C Roofing shingle and underlayment - physical sample from manufacturers.
  - C All interior finish trim materials and colors - finish manufacturer samples.
  - C Floor finishes - carpet, pad, vinyl, underlayment.
  - C HVAC heat/cooling load calculations. Manual J.
  - C All HVAC equipment - manufacturer submittals.
  - C All plumbing equipment and fixtures - manufacturer submittals. Include left- or right-hand qty.
  - C All required close-out documents and OEM manuals.
  - C Electrical service equipment and electrical panels.
- b. Submit three (3) copies of paperwork and one (1) physical sample (if required above) for approval. SBH will respond within three (3) days with approval, conditional approval, or rejection for revision and re-submittal. PDF emailed submittals in lieu of paper submittals are acceptable. Email submittals to Safa Saddawi at [safas@sbheritage.org](mailto:safas@sbheritage.org).
18. Schedule of Alternates: None.
19. Allowances: None.
20. Construction Facilities:
- a. SBH shall maintain at least one (1) complete full-size and bound set of Drawings and Specifications at the job site for all subcontractors to reference and make as-built notations.
  - b. Subcontractor to install temporary electric service. AEP accounts for temporary power is the responsibility of SBH.
  - c. Dumpsters provided and paid by SBH.
  - d. Port-a-potty shall be provided and maintained on site by SBH.
21. On-Site Storage: To the greatest extent possible, this project will operate with "just in time" delivery of all materials. Staging of materials on site outside of the period scheduled for that trade is not permitted unless pre-arranged with SBH and in Contractor-provided storage container. Storage of material for current use in structures already completed is not permitted. Staging of materials for more than one group at a time is not permitted unless pre-arranged with SBH and in contractor- provided storage container.
22. Safety: It is SBH's responsibility to maintain and enforce an environment of safe work practices at the job site.

23. Cutting, Notching, and Drilling: Structural floor members shall not be cut, bored or notched in excess of the limitations specified in section 502.8 of the Indiana Residential Code. Engineered lumber members shall not be cut or notched in excess of the limitations specified in the manufacturer's recommendations and in accordance with IRC Section 502.8.2.
24. Field Measurements: Each Contractor or Subcontractor shall obtain his own lines and/or grades and be responsible for the same.
25. Adjustment to Building Conditions: Contractor must obtain written consent of the Architect for any changes. Any change necessary to pass immovable obstructions shall be made by the Contractor without additional cost.
26. Anchor Bolts, Sleeves, etc.: Shall be set by each subcontractor requiring their use. Sleeves to be sealed by same as required by Local and State Codes.
27. Drawings: Drawings are not to be scaled; written dimensions will govern in all cases.
28. Lifting Devices and Hoisting Facilities: Shall be provided by each subcontractor. Proper bracing and safety equipment is required.

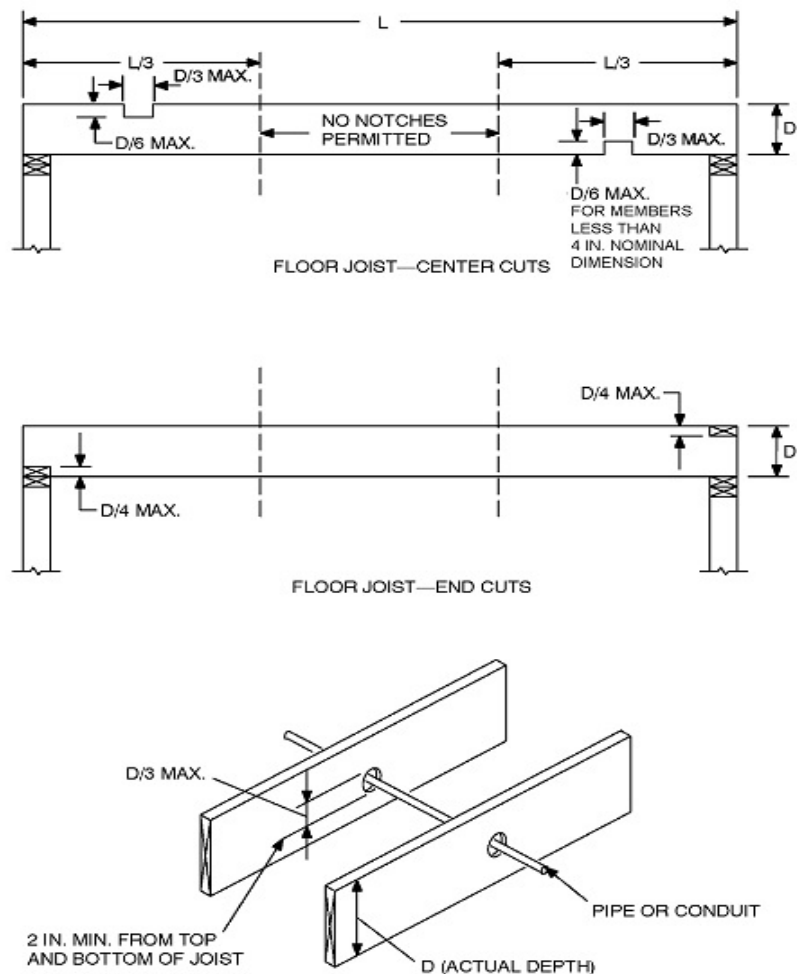

**FIGURE R502.8 CUTTING, NOTCHING AND DRILLING**

29. Job Site Debris and Cleaning: Premises will be left each day by each subcontractor broom clean. SBH is responsible to enforce a clean and tidy job site.
30. Temporary Controls:
  - a. Construction materials shall be stored off the ground and covered to avoid absorption of moisture and damage.
  - b. Mechanical ducts shall be sealed during construction.
  - c. Temporary Enclosures and Protection: To be provided by framing subcontractor unless noted otherwise. Give one (1) key each to Architect and Owner for all locks on doors.
31. Construction Sign: Subcontractor to furnish and erect an 8'-0" x 8'-0" construction sign at the site. The design and layout will be provided by the Architect.
32. Construction Waste Management:
  - a. All dumpsters by SBH.
  - b. Job site to be maintained in a clean and orderly condition. Each contractor is generally responsible for depositing debris generated by their work into the SBH provided dumpster.
33. Contract Closeout:
  - a. As defined in Construction Agreement.
  - b. Punch List Procedures: Contractors shall walk through each unit with SBH to determine the punch list and which items shall be monetized on the final punch list.
  - c. Operation and maintenance manuals of all systems shall be required.
  - d. Record Drawings: At the completion of the project, each subcontractor shall submit one (1) complete set of "as built" drawings, which highlights in red all changes which deviate from original contract documents.

C. DIVISION 2 - EXISTING CONDITIONS

1. Environmental Study: City of South bend, Community Development will be conducting the study.

D. DIVISION 3 - CONCRETE

1. All concrete shall be installed in accordance with ACI 318 of the American Concrete Institute with latest revisions.
2. Portland Cement: ASTM C150 Type 1 cement.
3. All exterior concrete for walks, step, and pads shall be a minimum 4,000 psi, maximum 4" slump, 4-7% air entrainment with limestone aggregate. Concrete placed in the City right-of-way shall be in accordance with South Bend Department of Public Works specifications. With coarse aggregate of 1-1/2" maximum size, either clean, hard washed, screened limestone or gravel free of dust and excess lime materials.
4. All footing and foundation wall concrete shall be minimum 3,000 psi, maximum 4" slump.



5. Fine aggregate shall consist of natural sand free of dust, lumps or flaky particles, shale, alkali, organic matter, loam or other deleterious material.
  6. Establish the top of foundation wall above at finish grade noted on Project Drawings.
  7. Foundation walls to be 8" thick reinforced concrete as shown on the Project Drawings.
  8. Reinforcing Steel: All reinforcing steel shall comply with ASTM E614 with a 305 deformation. Reinforcement shall be unpainted, uncoated and free from excessive rust, loose scale or other coating character which will reduce or destroy the bond.
  9. Reinforcing Fibers: Provide reinforcing fibers in all concrete slab-on-grade construction within the building. Fibers shall be polypropylene fibrillated fibers as manufactured by S1 Concrete Systems, Chattanooga, Tennessee or Architect approved equal.
  10. Welded Wire Fabric: Welded wire fabric shall conform to ASTM A185.
1. Foundation Anchors: Provide 1/2" diameter x 10" long Simpson Titan HD HDG within 12" of the corners and either side of door openings. Space bolts a maximum 6' oc. (U.N.O.).
  2. Where noted on the Project Drawings, install 4" Schedule 40 PVC pipe with "T" stubbed through slab for passive radon system. Locate as noted on Project Drawings. Provide 4' x 4' x 10" deep pit with pea gravel in lieu of granular subgrade material noted above. Center pit on radon pipe location.
  3. Drain tile: Install drain tile along footer where downspouts are noted to be connected to storm drainage system on the Project Drawings. Drain to be 4" diameter HDPE flex perforated pipe and fabric sleeve. Route to nearest yard inlet.
  4. Under slab Plumbing: All trenching for under slab plumbing shall be backfilled with granular material.
  5. Slab-on-Grade Installation: Prior to placing concrete floor slabs, inspect vapor barrier for proper connection to foundation wall and seal at all pipe penetrations. Repair as required.
  6. Install 2" perimeter rigid insulation on foundation wall.
  7. Vapor Barrier: Refer to Division 7.
  8. Porch deck and steps to be poured concrete. Refer to plans.
  9. Slabs-on-Grade: Sawcut control joints 25% of slab depth and spaced as shown on Project Drawings to coordinate with interior wall locations. Slope to drain.
  10. Concrete Walks, Curbs, etc.: Concrete shall be leveled off and troweled sufficiently to bring mortar to the surface then wood float finish. Provide expansion joints 3/8" thick pre-formed material (on 40' maximum centers and/or where shown on Project Drawings). Score walk transversely at intervals not exceeding with the walk. Walk cross-slope shall be maximum 2%.
  11. Curing: Freshly placed concrete shall be protected from pre-mature drying and excessively hot or cold temperatures. It shall be maintained in a moist condition and at a constant temperature for at least seven (7) days after placement. Use methods as approved by the Architect.
  12. Soils Check: All footing trenches, slab fill must be checked and approved an approved soils engineer prior to placing any concrete. Such checks will be at the Contractor's expense, and it will be the sole responsibility of the Contractor to notify the soils engineer at such times as the inspection is required.

13. Concrete Replacement: In the event concrete is placed which does not meet or exceed the strength requirements as herein specified, all such concrete shall be removed and replaced with concrete of the specified strength. This removal and replacement shall be at the Contractor's expense.
14. Cast-in-Place Concrete Finishes: Interior floor slabs shall receive steel trowel finish. Exterior concrete slabs, walks, stoops, etc., shall have a broom finish.
- 15.

E. DIVISION 4 - MASONRY (Not Applicable)

F. DIVISION 5 - METALS

1. Fasteners and Connections: Per details and Specifications. Simpson Strong Tie (SST) or approved equal.
2. Roof Truss/Wall Clips: Shall be Simpson STC Clips. Utilize at non-bearing interior walls.
3. Steel rebar and reinforcing mesh to meet or exceed IBC and IRC 2018 requirements.
4. Aluminum flashing per Drawings. .027" minimum thickness, prefinished where visible on the exterior of the building.

G. DIVISION 6 - WOOD AND PLASTICS

1. Rough Carpentry:

a. Framing and Rough Carpentry:

- 1) All lumber shall be grade-stamped by an agency certified by the Board of Review of the American Lumber Standards Committee as of 1991. Lumber shall be graded as follows:
- 2) Interior and Exterior Load Bearing and Non-Load Bearing 2 x 4 Wall Framing (Less Than 8' Long): Stud Grade "SPF" (Spruce/Pine/Fir) with moisture content not exceeding 19%. Studs installed vertically shall be finger jointed.
- 3) Interior and Exterior Load Bearing and Non-Load Bearing Wall Framing 2 x 6 and Larger and 2 x 4 8' or Longer: No. 2 or Better "SPF" (Spruce/Pine/Fir) with moisture content not exceeding 19%. Studs installed vertically shall be finger jointed.
- 4) Wall Plates, Blocking and Furring: No. 1/2 "SPF" (Spruce/Pine/Fir) with moisture content not exceeding 19%.
- 5) Structural Framing Members (Rafters, Joists, Rim Boards, Wall Framing Members, Headers and Beams Over 10' long, etc.): So. Pine. No. 2. Refer to Drawings for requirements of structural members noted which may differ from those specified herein. In case of discrepancies, the larger specified value will govern.

b. Engineered Framing Materials:

- 1) Laminated Veneer Lumber (LVL): Microllam LVL by Weyerhaeuser Trus Joist Engineered Wood Products or equal (Fb = 2,600 psi, E = 2.0 x 10<sup>6</sup>, Fv = 285 psi, minimums).
- 2) Parallel Strand Lumber (PSL): Shall be Parallam as manufactured by Weyerhaeuser Corporation or Architect approved equal. Properties of PSL shall be E = 2.0 x 106 PSI, Fb = 2,900 PSI, Fv = 290 PSI. Sizes shall be as noted on Drawings.

- 3) I Joists: TJI Joists by Weyerhaeuser Trus Joist Engineered Wood Products or equal. Comply with all manufacturer's requirements for detailing - including allowable hole cut limitations.
  - 4) Rim Board: 1-1/8" thick TJ Rim Board by Trust Joist Engineered Wood Products.
- c. Penalization and stick-framing are both acceptable base bid approaches. Please note your chosen approach on the bid form. Install post-installed foundation anchors within 12" of each corner, either side of doors, and max. 6' OC unless noted otherwise.
- d. Floor Sheathing: APA 48/24, 3/4" or 23/32" sheathing and single-floor rated T & G sheathing, PS 1 EXT. Floor sheathing with butt joint construction shall be installed with joint spacing of 1/8" or less. All joints greater than 1/8" shall be filled so as to provide a solid substrate for installation of lightweight concrete.
- e. Roof Sheathing: 1/2" APA rated sheathing, Exposure 1 with span rating 24/16. Nail with 8d nails at 6" o.c. on edges and 12" o.c. intermediate.
- f. Composite Insulating Wall Sheathing: Oriented-Strand-Board, Exposure 1 Sheathing, 7/16" thick with factory-laminated, water-resistive barrier exterior facer, and with rigid foam plastic insulating board laminated to interior face. Reference NATIONAL GREEN BUILDING STANDARD DESIGN REQUIREMENTS, Paragraph C. Execution, Subparagraph 1(a)(28) Air Barrier, Air Sealing, Building Envelope Testing, and Insulation 701.4.3.2.
- 1) Provide Huber Engineered Woods, LLC, zip system "R" sheathing.
  - 2) Span Rating and Performance Category of Sheathing Layer: Not less than 24/16; 7/16 Performance Category.
  - 3) Thickness: 1-1/2".
  - 4) Thermal Resistivity: R Value 6.6 deg F x h x sq.ft./BTU x in. x 75 deg F.
  - 5) Edge Profile: Square edge.
  - 6) Exterior Facer: Medium-density; phenolic-impregnated polymer-modified sheet material meeting requirements for ASTM D779 Grade D weather-resistive barrier in accordance with ICC AC38 and AC310, with fastener spacing symbols in exterior facer for 16" in center spacing, with the following characteristics.
    - a) Water Resistance of Coatings, ASTM S2247: Pass 14-day exposure test.
    - b) Moisture Vapor Transmission, ASTM E96: Not less than 12 perms.
    - c) Water Penetration, ASTM E331: Pass at 2.86 lbf/dt.
    - d) Wind Driven Rain, TAS-100: Pass.
    - e) Accelerated Weathering, ASTM G154: Pass.
  - 7) Fasteners:
    - a) Fasteners, General: Size and type complying with manufacturer's written instructions for project conditions and requirements of authorities having jurisdiction.
    - b) Corrosion Resistance: Hot-dipped zinc coating, ASTM A153/A153M.
    - c) Nails, Brads, and Staples: ICC AC116 and ICC AC201.
    - d) Power Driven Fasteners: ICC-ES-1539 or NER-272.
    - e) Wood Screws: ASME B 18.6.1.
  - 8) Sheathing Joint and Penetration Treatment Material:
    - a) Self-Adhering Stem and Flashing Tape: Pressure-sensitive, self-adhering, cold-applied, seam tape consisting of polyolefin film with acrylic adhesive, meeting ICC AC148.
      - (1) Basis of Design Products: Provide Huber Engineered Woods; Zip System Tape.
        - (a) Thickness: 0.012".
  - 9) Insulating Composite Wall Sheathing Installation:
    - a) Install sheathing panels in accordance with manufacturer's written instructions, requirements of applicable Evaluation Reports, and requirements of authorities having jurisdiction.

- b) Air and Moisture Barrier: Coordinate sheathing installation with flashing and joint sealant installation and with adjacent building air and moisture barrier components to provide complete, continuous air and moisture barrier.
- c) Do not bridge expansion joints; allow joint spacing equal to spacing of structural supports. Install cut panel edges adjacent to uncut panels with remaining sheathing reveal or to outside corner.
- d) Install panels with laminated facer to exterior.
- e) Stagger end joints of adjacent panel runs.
- f) Attach sheathing panels securely to substrate with manufacturer-approved fasteners in compliance with the following:
  - (1) IBC: Table 2304.9.1 Fastening Schedule.
  - (2) Fastener spacing shall be in accordance with the structural drawings.
- g) Apply seam tape to all panel seams, penetrations, and facer defects or cracks to form continuous weathertight surface.

Apply tape according to manufacturer's written instructions and requirements of ICC-ES applicable to tape application.

- g. Wall Sheathing: ½" APA rated sheathing, PS1, Exposure 1 with span rating 24/16. Nail with 8d nails at 6" o.c. edge and 12" o.c. intermediate unless noted otherwise. Provide at exterior walls and shear walls as noted.
- h. Shear Wall Sheathing (Interior Use): Shall be 3/8" plywood or OSB APA 24/16 sheathing rated exposure 1 with butt joints.
- i. 3/4" fire-resistant plywood at all electrical panels. 4' x 4' sheet at each duplex building. See elevations for size, and coordinate with electrical equipment being supplied.
- j. Draftstop Sheathing: Thermo-Ply Standard Structural Grade Sheathing by OX Industries.
- k. All trusses for all structures to be designed with energy heel height noted on the Drawings.

2. Exterior Stair Rail: 1-1/4" Schedule 40, A316 stainless steel. Submit shop drawings.

- a. Wood Preservatives: All wood in contact with concrete or masonry, except interior wall plates, shall be pressure treated. Retention to be 0.40 minimum.
- b. Provide and install 2x blocking. Inspect Drawings for all cabinetry, shelves, handrails, towel bars, toilet paper holder, grab bars, mirrors, shower rods, etc., and provide 2x blocking as required. 2x blocking to be provided in all standard unit bathrooms to allow future addition toilet grab bars per Fair Housing Act. Shower units shall have integral backing for grab bars and shower seats per Fair Housing Guidelines and the ADA.

Provide blocking to secure fiberglass shower edges and additional framing as required to secure any interior walls for lateral stability.

3. Shop Fabricated Wood Trusses:

- a. Shop Drawings and Structural Calculations:
  - 1) Furnish complete shop drawings and erection drawings showing all components.
  - 2) The shop drawings shall include a copy of the structural design calculations stamped and certified by an Architect or Engineer registered in the State of Indiana.
  - 3) The fabricator shall be responsible for the design of all members.
    - a) Design in accordance with all applicable state and local building codes and regulations.
    - b) Design members for all dead, live and suspended loads as noted on

- c) Coordinate with the Architect for connections and details.
  - d) Sizes of prefabricated members shown on the Drawings are for architectural purposes and are not to be construed to mean they are sized for structural adequacy.
  - e) Fabricator must immediately notify Architect if sizes shown are insufficient to meet the design criteria.
- 4) Shop drawings shall also include bracing and bridging and installation instructions. Obtain Architect's approval prior to fabricating any materials or proceeding with the work.
- b. Design Requirements:
- 1) All members shall be designed in accordance with live and dead loads as shown on the Drawings using allowable properties for the materials in accordance with AITC Specification No. 117 for dry conditions of use.
  - 2) Deflection Criteria:
    - a) Floor Trusses ( $E = 1.9 \times 10^6$  psi minimum) Maximum live load deflection =  $L/480$  Maximum total deflection =  $L/360$   
Maximum live load deflection over doors and windows =  $1/2"$
    - b) Roof Trusses  
Maximum live load deflection =  $L/360$   
Maximum total deflection =  $L/240$   
Maximum live load deflection over doors and windows =  $1/2"$
  - 3) Camber:
    - a) Camber all beams and floor trusses for 1.5 times the dead load deflection.
    - b) Camber all roof trusses for total dead load deflection plus  $1/2$  live load deflection.
    - c) Tolerance on camber shall be  $1/4" \pm$ .
- c. Standards:
- 1) Wood Trusses: Truss girders and roof trusses shall be as shown on the Drawings.
  - 2) Units are to be manufactured in strict accordance with the manufacturer's printed details and as approved by the TPI design specifications for metal plate connected wood trusses and NFPA NDS.
4. Wood I-Joists:
- a. Code Approvals: All products shall be designed and manufactured to the standards set forth in the ICC Evaluation Service, Inc. Report ESR-1153.
  - b. Products:
    - 1) "Trus Joist" products as manufactured by Weyerhaeuser.
    - 2) Wood I-joists shall be designed to fit the dimensions and loads as shown on the Drawings.
  - c. Shop Drawings:
    - 1) Submit shop drawings showing layout and detail necessary for determining fit and placement in the building.
    - 2) Fabrication shall not proceed until Architect or Engineer has approved all submittals.
  - d. Materials:
    - 1) Flange members, web members, and adhesives shall conform to provisions of the ICC-ES ESR-1153.
      - a) TJI 11-7/8" - 210.
      - b) TJI 16" - 230.
  - e. Identification: Each joist and rim board shall be identified by a stamp indicating the

series and ICC-ES Report, number, manufacturer's name, plant number and the independent inspection agency's logo.

f. Installation:

- 1) Contractor shall give notification to the Architect and manufacturer prior to installation of Truss Joist products to review and discuss product installation guidelines.
- 2) Performance Standards: Products shall be proven by testing and evaluation in accordance with the provisions of ASTM D5055.
- 3) Fire Rating/Sound Ratings: Fire and sound ratings are to be established in accordance with assemblies as detailed in ICC ES ESR-1153 or the *Directory of Listed Products*, published by Intertek Testing Services.
- 4) Warranty: The products delivered shall be free from manufacturing errors or defects in workmanship and material. The products, when correctly installed and maintained, shall be warranted to perform as designed for the normal and expected life of the building.

5. Soffits: See Drawings for 2x framed soffits and lowered ceiling at kitchen above the cupboards.

6. Finish Carpentry:

a. Countertops:

- 1) Plastic Laminate: Formica or equal (matte finish) with B-D Interior APA plywood or particle board backing. Provide post formed back splashes and applied end splashes at counter tops. Minimize countertop seams to the greatest extent possible. Submit sample for Owner approval.
- 2) Bathroom Countertops: Shall be Swanstone Ellipse vanity tops, 22" deep with matching side splash. Where fit between walls, trim sides equally to maintain sink centerline.
- 3) Provide mounting blocks for range hood as required at wall cabinet over range.

b. Window Sills: Shall be imitation marble with 3/4" overhang.

c. Medicine Cabinet/Mirror in Full Bathrooms: Install recessed medicine cabinet for any full bath. provide Jensen model #615 cabinets with woodgrain surface and a separate mirror. Mirror for other bathrooms.

d. Install the following accessories in each bathroom:

- 1) 1x towel bar (24") in half bathrooms.
- 2) 1x towel bars (24") in full bathrooms with 1x towel bar (18") or one (1) towel hook. See Drawings for designation and type.
- 3) 1x toilet paper holder.
- 4) 24 x 36 mirror. Mount 40" max. a.f.f.
- 5) Shower curtain rod at each tub/shower. single, straight rod with screw attachment. 72" a.f.f.

Color of bathroom accessories to be brushed nickel. Provide shop drawings, product data and samples for Owner or Architect approval.

e. Interior Trim:

- 1) Interior door casing, trim is 1 1/16" x 3.5" colonial factory PFJ. "Picture frame" each door opening. At windows, install casing trim apron at sill.
- 2) Except where vinyl base is noted, baseboard is 9/16" x 5.25" colonial base factory PFJ. Cope all inside corners.
- 3) 1/2" x 3/4" base-shoe at all non-carpeted floor edges where wood base is installed.
- 4) 1x skirt trim at all stairways. Painted.
- 5) Interior doors are pre-hung and primed. Refer to Division 8.

- f. Shelves:
- 1) All linen and closet shelves to be 1 x 12 solid wood or prefinished melamine material.
  - 2) All laundry room shelves to be 12" deep wire system.
  - 3) Cleats and metal shelf support brackets secured to framing. Brackets 48" OC maximum.
  - 4) Hanging rods to be 1-1/4" dia. wooden dowel.
- g. Stairs:
- 1) From First Floor to Second Floor at duplexes and townhouses shall be finished as follows:
    - a) Half wall cap where occurs - 5/4 oak, Stain/polyurethane finish. Eased edges.
    - b) Stair treads and risers to be carpeted.
- h. Railings:
- 1) Interior Stair Rail: 1-3/4" unfinished solid red oak wall rail. Return to wall as required.
    - a) Mounting Bracket: 2-3/4 x 2-3/4" matte black prefinished wrought iron handrail bracket as manufactured by L.J. Smith Stair Systems.
  - 2) Exterior Stair Rail: See Division 5 for material.
- i. Wood Brackets: 4 x 6 timber, southern yellow pine.
- j. Porch Columns:
- a) Manufacturer: Melton Classics, Inc., Lawrenceville, Georgia (800-963-3060).
  - b) Meltoncraft Tuscan style column cover, 8" x 8'-0" (V.I.F.), square, no taper. (Column finish is to be field installed paint. See Division 9.
7. Vented Soffits (Eave and Rake Areas): Perforated aluminum panel. Color per schedule. Reference NATIONAL GREEN BUILDING STANDARD DESIGN REQUIREMENTS, Paragraph C. Execution, Subparagraph 1(a)(10) Prefinished Materials 601.7.
8. Front Porch Soffit: Beaded wood panels. Stained.
9. Exterior Trim: Reference NATIONAL GREEN BUILDING STANDARD DESIGN REQUIREMENTS, Paragraph C. Execution, Subparagraph 1(a)(10) Prefinished Materials 601.7.
- a. Manufacturer: Azek Exteriors, the Azek Company, 1330 West Fulton Street, Suite 350, Chicago, IL 60607.
  - b. Rake End Trim: Azek 5/4 x 5-1/2" Trim Board (smooth).
  - c. Frieze Board with Crown:
    - 1) Azek 5/4 x 10 Trim Board (smooth).
    - 2) Azek Ram's Crown (AZM-6934).
  - d. Corner Trim:
    - 1) Azek 5/4 x 7-1/4" wide.
    - 2) Azek 5/4 x 3-1/2" wide.
- e. Window Trim:
- 1) Head:
    - a) Azek 4/4 x 2 Cap, over.
    - b) Azek 5/4 x 6 Trim Board (smooth).

- 2) Jamb: Azek 5/4 x 4 Trim Board (smooth).
  - 3) Sill: Azek Historic Sill (AZM-6930).
- f. Band Board Trim: Azek 5/4 x 7-1/4" (smooth).
- g. Skirt Board:
- 1) Azek Water Table (AZM-6935).
  - 2) Azek 5/4 x 10 Trim Board (smooth).

Paint all cut ends prior to installation.

- 1) Columns: Meltoncraft cellular PVC columns:

## H. DIVISION 7 - THERMAL AND MOISTURE PROTECTION

1. Exterior Siding:
  - a. Vinyl Clapboard Siding: CertainTeed Monogram .046 double 5" vinyl siding and associated accessory trims, starter strips, J-channel, and incidental materials as otherwise selected for a complete job, smooth finish. Color to be selected by Architect.
    - 1) CertainTeed Vinyl Mounting Blocks: Dryer vent, exhaust vent, kitchen hood vent, lighting, etc. Match siding color. Submit appropriate mounting block to Architect for review.
  - b. Vinyl Shingle Siding: CertainTeed Cedar Impressions Triple 5" Straight Edge Sawmill Shingles, or equivalent, polymer based, to comply with ASTM D7254. Color to be selected by Architect from manufacturer's standard colors.
  - c. Board and Batten: CertainTeed Single 8" Vertical Board and Batten, vinyl, rough cedar finish. Color to be selected by Architect from manufacturer's standard colors.
2. Gable End Vent: 0.019 aluminum, standard integral nailing fin, fiberglass insect screen, triangle gable vent as manufactured by American Louver and Vent. Baked-on enamel finish. Color by Architect.
3. DuPont Tyvek: Building wrap by DuPont. Install per manufacture specification.
4. Flex Tape:
5. Vapor Barrier: Under slab; Stego Wrap Vapor Barrier (15 mil) by Stego Industries, LLC. Extend vapor barrier to perimeter of slab. Seal vapor barrier to foundation wall.
6. Cellulose Insulation (Attic): See Drawings for insulation types, R-values, and locations. Loose blown attics to be R38.
7. Insulation Baffle: Owens Corning Raft-R-Mate 22-1/2" x 48" Attic Insulation Rafter Baffle, proper vents.
8. Fiberglass Batt Insulation (Walls): R15 at stud wall with kraft paper vapor barrier. At Contractor's option, provide cellulose insulation, minimum R15.
9. Fiberglass Batt Insulation (Cathedral Ceiling): R38 with kraft paper vapor barrier.
10. Refer to Division 8 for attic scuttle insulation cut sheet.
11. Spray Foam - Closed Cell:
  - a. Rim Joist Seal: At two-story structures only, between first and second floor, 2-1/2" closed cell 2 PCF spray foam from top of first floor top plate to underside of floor deck above.



- b. Behind All Exterior Wall Electrical Boxes: Low expansion closed cell foam to seal box.
12. Low Expansion Foam: At windows and doors perimeters. Foam bead to be continuous.
13. Dimensional Fiberglass Asphalt Roof Shingles and Underlayment:
- a. Acceptable Manufacturers: Owen Corning® Oakridge II (30yr); GAF Timberline "Natural Shadow"; approved equal.
  - b. Colors per schedule are chosen from the GAF line. Assume similar colors for other manufacturers. Submittal required.
  - c. Includes matching starter strip, ridge cap.
  - d. Install per manufacturer specifications over underlayment per Drawings.
- See Drawings for roof deck details including minimum .027 pre-finished flashing/drips/fascia; continuous ridge vent; and self-adhered ice/water shield. Install ice/water shield at roof eaves only.
14. Ice and Water Membrane:
- a. At eaves and as otherwise required by code.
  - b. Acceptable Manufacturers: GAF "Stormguard"; Owens Corning "Weatherlock Flex Flexible"; approved equal.
    - a) Meltoncraft column cover, 6" x 8'-0" (V.I.F.), square, no taper.
15. Fascia Drip Edge: "D-Style", 0.032" aluminum, Kynar finish shingle roof drip edge as manufactured by K & M Sheet Metal. Color by Architect.
1. Roof Ridge Vent:
- a. Continuous ridge vent.
  - b. Acceptable Manufacturers: Cor-A-Vent; GAF Cobra; or approved equal.
2. Aluminum Gutters and Downspouts: Provide continuous gutters and downspouts, with prefinished aluminum and 1/8" per foot slope minimum. Fasten according to manufacturer's recommendation. Provide splash guards at all down spouts. Provide product data and samples for Owner or Architect approval.
3. Sill Sealer: Provide Conservation Technology structural gaskets BG63 at wall plates on foundation walls.
4. Sealant:
- c. Continuous draftstop bead between the subfloor and the bottom exterior wall plate at upper floor walls.
  - d. Set all ext. door thresholds in continuous bead of sealant. One (1) 10-oz. tube per door.
  - e. Set all windows sills in continuous bead of sealant. Alternately, windows may be shimmed up to allow for low expansion foam below sill by insulation contractor. Verify window RO. Coordinate with WRB installation specifications.
  - f. Where noted elsewhere in Specifications.
  - g. Wallboard gap around bath fans installed into ceilings shared with attic.

- h. At attic scuttle per manufacturer's spec.
- i. Mechanical penetrations between unconditioned spaces and conditioned spaces or wall cavities.

Acceptable Sealant Manufacturers: Dow Corning 795; Tremco Spectrum 2; approved equal.

5. Sealant/Caulk - Other Locations:

- j. Sealant at tub/flooring edge and stool perimeter noted under Division 15.
- k. Exposed caulk/sealants at painted trim per Division 9.

Caulk used at interior and exterior exposed painted surfaces may be acrylic latex. Paintable. Acceptable manufacturer: DAP Alex Plus acrylic latex caulk plus silicone 35 year; approved equal.

6. Fire resistant caulking to be 3M Fire Barrier Sealant system or approved equal.

7. Gypsum Wallboard Adhesive: Continuous bead:

- l. Between the bottom plate and the drywall; and
- m. Between the top plate and the drywall; and
- n. Around window and door RO's.

8. Window Sill Adhesive:

- o. "Nail Power Premium Quality Construction Panel Adhesive" as manufactured by:
  - 1) Magic Seal Corporation.
  - 2) Or Architect-approved equal.

9. Subfloor Adhesive: "Nail Power Subfloor Construction Adhesive" as manufactured by Magic Seal Corporation or Architect-approved equal.

I. DIVISION 8 - OPENINGS

1. General: Provide shop drawings, product data and samples for Owner or Architect approval. Refer to Door and Window Schedules for additional information.

2. Interior Doors, Hardware, and Keys:

- a. Craftmaster 1-3/8" Carrara smooth panel interior door. Pre-hung pine jambs eased edge stop, and satin nickel hinges. Door panel and frames to be pre-finished.
- b. CC to provide interior pocket door frames by framer where occurs.
- c. Hardware: Schlage lever style handle - Accent or Flair; Finish: Satin Nickel; Passage function for all interior doors unless noted otherwise; Bathroom door locksets shall be Privacy function with standard emergency unlock feature; Closet doors to match; install door bumpers/stops throughout.
- d. Undercut all interior doors 1/2" a.f.f.

3. Exterior Entry Doors (General):

Temporary Entry Doors: Install temporary door panel into the installed frames at front and rear entry door locations. Provide keyed construction lock. Provide SBH with keys for distribution to contractors.

- a. Residential Front Entry Door: Therma-Tru, Smooth Star S606SDL fiberglass; per

schedule; Swing: as noted per Drawings; Finish: painted. No brick-mold trim. Provide exterior casing trim to match windows. Flashing per Division 7.

- b. Hardware - Front Entry Door (Duplexes): Schlage Front Entry Handleset - F60 Addison; Finish: Satin Nickel. F60ADD609FLAADD.
- c. Hardware - Rear Entry Door (Duplexes): Schlage security knob and deadbolt; Finish: Satin Nickel. F51A-619 with F series lever and matching deadbolt keyed alike.
- d. Keys: Provide Owner with 2 sets of keys for each house. Keys are each individual house and garage to match.

4. Attic Access Door:

- a. 22" x 42" Air-tight attic access scuttle door. Minimum R38. No lock option required.
- b. Acceptable Manufacturers: Battic Door EZ Hatch 42 or approved equal. Install per manufacturer specifications with sealants per Division 7.

5. Windows:

Pella 250 Series vinyl single- hung windows. Tempered where required by code. Maximum U-value: 0.29. Provide window opening control device (wood) complying with ASTM F2090 to all windows where sill is below 36" a.f.f. (reference I.B.C. Section 1013.8 Window Sills).

- a. Confirm bedroom window egress dimensions and area comply with the code.

J. DIVISION 9 - FINISHES

1. Gypsum Board:

- a. 1/2" thick board on all walls, ceilings, and stair ceilings leading to the second floor; 1/2" thick water resistant board on all walls and ceilings at tub/shower locations.
- b. 5/8", Type "X" gypsum board. Fire code "C" at fire-rated partitions, walls and ceilings where indicated on Drawings.
- c. Walls to be finished smooth. Uniform light knockdown texture on ceilings. Rated assemblies as required per Drawings/Wall Schedule.
- d. Submittals required for wallboard.

2. Paint Systems: Sherwin-Williams; approved equal.

a. Interior Paint:

- 1) Preparation of All Surfaces: Caulk and nail hole spackle.
- 2) Walls: One (1) coat primer + two (2) coat Eggshell finish; assume two (1) color different than ceiling color for all walls.
- 3) Ceilings: One (1) coat primer + one (1) coat flat finish; Sherwin-Williams ProMar 200.
- 4) Door Casing, Window Sill Aprons, Base: One (1) coat Semi-Gloss Finish (trim installed primed) and touch up as required; Sherwin-Williams Pro-Classic.
- 5) Walls: One (1) coat primer + two (2) coats satin finish; Sherwin-Williams Harmony Low VOC.
- 6) Windows: Prefinished.
- 7) Stair Stringers: Match trim painting specification.
- 8) Note that windows are installed pre-finished white semi-gloss.

b. Interior Colors:

- 1) All ceilings to be painted SW6119 "antique white" flat matte.
  - 2) All interior non-bedroom walls to be painted SW6106 "Kilim Beige" eggshell.
  - 3) All bedroom and bedroom closet walls to be SW6108 "Latte" eggshell.
  - 4) Provide color sample submittal for Owner or Architect approval.
- c. Exterior Paint:
- 1) Preparation of all surfaces, caulk, and prime paint prior to applying finish coat.
  - 2) Trim: Smooth, pre-primed surface - two (2) coat semi-gloss exterior latex.
  - 3) Composite Columns: Semi-gloss finish as per manufacturer's requirements. Provide paint color sample submittal for Owner or Architect approval.
  - 4) See Division 6 for description of aluminum soffit, fascia, porch ceiling, etc.
- d. Exterior face of exterior entry doors to be painted one of two accent colors.
- 1) Accent Colors: (refer to Division 6, exterior finish schedule for locations) Option #1: TBD  
Option #2: TBD
  - 2) Assume that all colors are deep (clear) base colors.
  - 3) Caulk used at interior and exterior exposed painted surfaces per Division 7. Color to be determined.
3. Floor Finish:
- a. All vinyl flooring to be click LVT floating floor. Waterproof with attached pad. 12mm wear layer. Color to be determined.
- 1) Submittal on vinyl LVT required.
  - 2) Location of Vinyl: Vinyl flooring to be at all kitchens, bathrooms, laundry areas, living rooms, and a 3' x 3' area inside front and rear door if not otherwise noted as vinyl.
4. Carpet Floor Finish:
- a. All carpet/pad must meet Carpet and Rug institute's Green Label certification.
  - b. Carpet to be min. 35oz. nylon cut textured pile with min. 3.5 wear rating and integral stain repellent. Color to be determined.
  - c. Install over .5" rebound pad with min. 6-lb. density.
  - d. Acceptable Manufacturers: Shaw; Armstrong; Mohawk; or approved equal.
  - e. Submittal on carpet and pad required.
  - f. Location of Carpet: Carpet to be at all bedrooms,
  - g. Carpet at stairs to second floor duplexes.
  - h. Transition strips to be aluminum. Color to be determined.

K. DIVISION 10 - SPECIALTIES

1. House Numbers: Metal min. 4" tall. Color: Black. Coordinate location of house numbers with SBH.
2. Mailboxes: USPS approved post-mounted horizontal metal mailbox. Color: Black. Minimum size: 8" wide x 10" tall x 21" deep. Mount +48" on decorative post (+42" at ADA units). See Site Plan for locations.

L. DIVISION 11 - EQUIPMENT

1. See Division 26 for appliances to be set in place, connected and tested.

M. DIVISION 12 - FURNISHINGS

1. Casework:

a. Acceptable Manufacturers:

- 1) Contractor's Choice.
- 2) Advanta Cabinets.
- 3) Kraftmaid.
- 4) Merillat.

b. Workmanship, General:

- 1) Machine parts for accurate fit and assemble with appropriate fastenings and adhesives to result in true, square, level, and plumb units.
- 2) Verify dimensions of other trades to be built into casework.
- 3) Scribe tops and backsplashes to walls and other adjoining vertical surfaces.
- 4) There shall be a 1-1/2" maximum scribe with casework at end walls unless shown otherwise.
- 5) Casework components shall be solid hardwood or hardwood plywood with wood veneer.
  - (1) No particleboard will be allowed.

c. Casework Construction:

- 1) All Cabinets shall be constructed of plywood.
- 2) Boxes:
  - a) Base Cabinets:
    - (1) Two Plywood Stretcher Rails.
    - (2) 3-8" Plywood Back, Bottom and Sides.
    - (3) 3/4" x 1 1/2" Solid Wood Face Frame with 3" Center Stile.
    - (4) 1/2" Half-Depth Plywood Shelf.
    - (5) 3/8" x 4" High Plywood Recessed Toe-Kick (Recessed 3 3/8" Deep).
  - b) Wall Cabinets:
    - (1) 1/2" Plywood Top and Bottom.
    - (2) 3/4" x 1 1/2" Solid Wood Face Frame.
    - (3) 3/8" Plywood Sides and Backs.
- 3) Fixed and Adjustable Shelves and Dividers:
  - a) 3/4" plywood with wood veneer and edge banding.
  - b) Number of adjustable shelves provided, unless indicated otherwise on the Drawings or on the Schedule:
    - (1) Tall Casework:
      - (a) Four (4) up to 84"
      - (b) Five (5) up to 90"
    - (2) Six (6) up to 96" Base Casework:
      - (a) One (1) up to 36"
    - (3) Wall-Hung Casework:

- (a) One (1) up to 24"
  - (b) Two (2) up to 30"
  - (c) Three (3) up to 42"
- 4) Doors:
- a) Doors shall be Contractor's Choice:
  - b) Hinged Doors (Unit Kitchens):
    - (1) Contractor's Choice "Newberry Birch", Color by Architect, stile and rail, square recessed panel.
    - (2) Doors 48" and less in height shall have two (2) hinges per door.
  - c) Hinged Doors (Community Room Kitchen):
    - (1) Contractor's Choice "Newberry Birch", Color by Architect, stile and rail, square recessed panel.
    - (2) Doors 48" and less in height shall have two (2) hinges per door.
- 5) Drawers:
- a) All wood drawer with 1/2" sides and back and 3/8" bottom.
  - b) All styles feature natural wood finish.
  - c) 20" deep drawer box with stapled butt joint construction.
  - d) Drawer bottom stapled into sides, front and back.
  - e) Self-closing, epoxy-coated guides for smooth, quiet action.
  - f) Rated at 100 lbs. capacity per drawer.
  - g) Adjustable side-mount drawer guides with double rails for more stability.
  - h) Built-in Drawer Stop.
  - i) Drawer Face:
    - (1) Constructed of 3/4" minimum plywood.
    - (2) Glued and dovetail jointed.
- 6) Cabinetry Pulls: At standard and visitable units, top and bottom door edges have 15-degree reverse bevel without pulls. Provide stainless steel 4" wire pulls at cabinet doors and drawers.
- 7) Finish: Multi-step process featuring stain sealer and multi-coat varnish.

d. Countertops: Refer to item G.5. Finish Carpentry.

2. Window Treatments: Purchased and installed by subcontractor.

3. Provide shop drawings, product data and samples for Owner or Architect approval.

N. DIVISION 22 - PLUMBING

1. Contractor shall furnish and install complete and efficient residential plumbing system. All work shall be in accordance with all applicable codes and is subject to City inspection(s). Make all final connections to City water and sewer systems.

2. Provide 5/8" water meter "ram's horn" base and fittings as required for City of South Bend 5/8" water meter. Installation of a ball valve shutoff at the 1" copper water supply line is to occur during plumbing rough in. Refer to Division 2 for information on water supply line from city stop valve.

3. Coordinate all below-slab plumbing and floor drains, with site and foundation work as required.

4. Potable Water:

a. Pipe:

PEX tubing complying with NSF 14, NSF 61, and ASTM F876/F877 may be used

Provide red piping for hot water and blue piping for cold water.

Fittings for PEX piping shall comply with ASTM F1807, ASTM F1865, ASTM F1960,

ASTM F2098 and ASTM F2159.

5. Waste, Vent and Storm:
  - a. PVC pipe Schedule 40 with DWV style fittings.
    - 1) Shall meet deflection standards of ASTM D3033.
  - b. NO-HUB cast iron pipe and fittings.
6. Condensate Piping:
  - a. PVC pipe Schedule 40 with DWV style fittings.
7. Provide and install PEX water supply lines to all plumbing fixtures, water heater and appliances. No PEX joints permitted inside wall cavities except at necessary branch fittings to fixture termination devices. Either color code (a) all cold as blue and hot as red or (b) all white.
  - a. Distribution system to be branch layout.
  - b. Install PEX per manufacturer specifications with appropriate supports, clips, and required accessories.
  - c. Recessed laundry box at all washer/dryer locations.
8. All exterior mechanical penetrations through the WRB per Division 7.  
Provide braided SS connections at water closets, lavatories and kitchen sink. Locate water closet connection 3" above top of baseboard trim for stools located against interior walls.
9. Quarter turn shutoff valve at each plumbing fixture connection. Dishwasher connection in kitchen sink base cabinet to be dual valve such that dishwasher can be isolated from the kitchen faucet.
10. Provide and install two (2) exterior hose bibb faucets (freeze proof) per building at duplexes.  
See apartment plumbing drawings for hose bibb locations. Plumb separate soft water system loop adjacent to water heater for future use.
11. Provide and install one (1) PVC floor drain in unit mechanical room.  
Cutting, notching, and drilling of structural members per the code and per manufacture
12. Pipe Installation:
  - a. Run piping straight and direct as possible, parallel with walls, partitions, structural elements and other piping and neatly spaced for service and insulation. Hang piping at or in ceiling from construction above, as close as possible to bottom of slabs, beams, etc. Maintain maximum headroom at all times. Coordinate with other trades prior to installation.
  - b. Pipe shall be cut accurately to measurements established at building and shall be worked into place without springing or forcing.
  - c. Arrange piping for maximum accessibility for maintenance and repair, and to properly clear windows, doors and other openings.
  - d. Use reducing fittings for changes in pipe sizes.
  - e. Provide dielectric couplings wherever copper and ferrous pressure pipe and/or fittings meet.
  - f. Install piping isolators at each pipe hanger and pipe support for hot and cold-water piping. Isolators shall be galvanized steel with felt padding by Tolco or

Elmdor/Stoneman.

13. Fire caulk to be 3M Fire Barrier Sealant system or approved equal.
14. Sealants: Clear silicone sealant at base of stool at drop-in lavatories.
15. Protect tubs during construction with cardboard or equivalent tub liner.
16. Water Heaters
  - a. See Water Heater Schedule on the Drawings. Acceptable water heater manufacturers are Bradford White; State; Rheem.
  - b. Energy factor to be  $\geq 0.64$  at duplexes.
  - c. Water heater insulation blanket is not required. Water heater installation must have heat traps in the piping connection design.
  - d. provide B-vent to roof with vent cap.
17. Plumbing Fixtures: Provide shop drawings and product data for Owner or Architect approval. Verify left/right-handed for each location per plans and site plan.

O. DIVISION 23 - HVAC

1. Contractor shall furnish and install complete and efficient residential HVAC system. All work shall be in accordance with all applicable codes and is subject to City inspection(s). Make all final connections to water, sewer and gas systems.
2. System Design: HVAC contractor to provide written heating and cooling calculations to verify equipment and ductwork sizes. Manual J. Provide these calculations after Contract award and before start of work. Coordinate any required adjustments or changes with the Architect.
3. HVAC Equipment:
  - a. Acceptable HVAC Equipment Manufacturers: York; Goodman; Carrier; Rheem; Lennox; Armstrong. See Furnace Schedule on the Drawings.
  - b. Gas furnaces shall be minimum 95% efficient with matched direct expansion coil.
  - c. Provide filter slot with sliding closure panel. Filter to be standard 1" type and sized for airflow. Provide filter. AC unit shall meet SEER<sup>2</sup> of 14 min.
4. Above-Ground Ductwork:
  - a. All rigid ductworks shall be galvanized steel, fabricated and installed according to the latest edition of the SMACNA HVAC Duct Construction Standards, with ducts cross-broken (all flat surfaces greater than 12" in any direction), braced and stiffened with turning vanes in all square elbows. Minimum gauge shall be as follows:
    - 1) Exposed ductwork shall be 26 gauge minimum except where flexible ductwork is shown on Drawings.
    - 2) Concealed ductwork over 14" shall be 28 gauge minimum. Where rectangular ducts are installed against two gypsum board surfaces, duct board with reinforced Foil Face Scrim may be used.
    - 3) Concealed ductwork under 14", including boots and connections, shall be 30 gauge minimum.



- b. All supply air ducts, all outside air ducts, exhaust ducts in the attic and all mixed air ducts shall be insulated with blanket fiberglass, 1-1/2" thickness, with FSK vapor barrier. Fiberglass insulation shall have a minimum density of 1.5 pcf. Insulation shall be Owens-Corning, or Manville. Seal all joints, seams and edges with matching FSK tape.
  - c. Flexible duct shall be Thermaflex or Architect-approved equal. Provide Flex Flow elbow duct support at all 90° bends. Ducts shall be M-KC series with R4.2 in heated space and R6 in the attic.
  - d. See Plumbing Fixture Schedule on the Drawings.
5. Grilles, Registers, Diffusers and Louvers: Titus, Hart & Cooley or approved equal. Diffusers shall be multi-directional unless indicated otherwise on Drawings. All air outlets must be supplied with an integral balancing device.
6. All ductwork joints, seams, collars, cleats, and connections to be sealed with specified mastic or UL181 rated tape. Framed bays that served as RA chases to be checked and sealed/caulked prior to wallboard installation, especially at cavity tops and where they connect through floor assemblies.
7. Natural Gas:
- Provide gas supply piping to all listed gas appliances. Shut offs, drip legs, and other as required. Coordinate gas line pressure test with city of South Bend inspector at same time as rough-in inspection.
- a. Pipe: Black steel, ASTM A53 or A106 Grade B, Schedule 40, furnace welded or seamless.
  - b. Fittings:
    - 1) Malleable Iron Fittings: ASTM A47, class 150, ANSI B16.3 (except gas over 2 psi).
    - 2) Welded Fittings (Butt Welded): ASTM A234, Grade B, WPB, ANSI B16.9.
  - c. Piping 2" and Smaller: Screwed fittings (except gas over 2 psi).
- Installation, testing, and inspection of the gas piping from the gas meter location to the furnace are to occur during rough-in. All exterior mechanical penetrations through the WRB per Division 7.
8. Cutting, notching, and drilling or structural members per code and per manufacturer's recommendations.
9. Provide and install all dryer vent ducts, exterior wall vent caps, recessed wall boxes behind dryers. Seal all venting ductwork joints and connections with alum. tape or fluid applied mastic duct sealant. Recessed clothes dryer box may be plastic type. No flex or semi-rigid duct is permitted.
10. Exterior dryer vent closure mounted on 5/4 wood trim block sized for vent. Acceptable dryer vent caps are Heartland; Lambro Ind. 289W; approved equal. Where vents occur in soffit, provide Deflecto "Undereve Vent".
11. Condensate Drain: 3/4" PVC piping. Extend to drain with 1/2"/10 feet slope minimum.
12. Thermostat: Hardwired. Programmable. Honeywell RTH7500D or approved equal.
13. The following appliances shall be provided:
- a. Range Hood: Vented to exterior at kitchen range. Broan QML30WW. 3.25" x 10" ducted to exterior via wall cabinet above unit. Provide Broan 639 wall cap.

- 1) Duct sealing and sealant at WRB per Division 7.
- 2) Main bathroom exhaust fan: Central bathroom exhaust fan to be Broan Ultra ZB80L. 4" rigid ducted. Sealed duct joints. Wired for continuous operation to meet ASHRAE Standard 62.2. Light, night light, and fan operation switched separately. For sidewall, vent fan wall cap to be Broan 885BL. For soffit, vent fan wall cap to be Lambro 143W; Duraflo; or approved equal. White. Flex aluminum duct allowed for connection of cap to rigid duct penetration at WRB only. Duct sealing and sealant at WRB per Division 7. Electric control device provided by EC.
- 3) Half bathroom exhaust fan: For duplex with more than one bathroom, such as a half bath, additional exhaust fan to be NuTone 769RFT. 4" rigid ducted. Sealed duct joints. Fan and light switched separately. No continuous operation required. For sidewall, vent fan wall cap to be Broan 885BL. For soffit, vent fan wall cap to be Lambro 143W; Duraflo; or approved equal. White. Flex aluminum duct allowed for connection of cap to rigid duct penetration at WRB only. Duct sealing and sealant at WRB per Division 7. Electric control switch provided by EC.

P. DIVISION 26 - ELECTRICAL

1. Contractor shall furnish and install complete 100-amp electrical service.
  - a. 24 slot main breaker panel surface mounted on fire resistant plywood panel.
  - b. See Exhaust Fan Schedule on the Drawings.
    - a. Acceptable Manufacturers: Square D; Siemens ITE;
    - b. Clearly print description of each circuit at breaker box.
  - c. All work shall be in accordance with all applicable codes and is subject to City of South Bend inspection(s).
  - d. Electrical service to the house is to be underground.
2. Meter bases to be installed on trim block provided by siding contractor. Do not install meter base directly to sheathing or WRB. Coordination is required per Division 7.
3. Temporary Power: Where noted on schedule, provide 4 x 4 post, plywood panel, meter base, breaker box, and two (2) quad exterior GFCI receptacles. Overhead service cable coordinated with Owner and electric utility.
4. Coordinate phone/data and cable services, installation, routing and connections with Owner. Coordinate with utility providers for underground drops. Provide cable connection in each bedroom and living room. Route each cable to location on plywood adjacent to electrical panel. Leave looped at panel without termination.
 

Phone wiring to be CAT-6E. Coaxial wire to be RG6.

No daisy-chain configuration - each cable and coaxial wire is separate. Terminate each cable at wall plate.
5. All exterior mechanical penetrations through the WRB per Division 7.
6. Wiring:

- a. Wiring Materials:
  - 1) Wire to be 98% conductivity soft or annealed copper, to ASTM specifications.
  - 2) Wire insulation must conform to all IPCEA and NEMA Standards for voltage and environmental conditions encountered.
- b. Wire Sizes: Sizes to be not less than indicated. Branch circuit wire to be No. 12 AWG minimum. Wire for branch circuits of 120 volts, more than 100' long, from panel to load center, to be No. 10 AWG minimum.

7. Devices:

- a. Materials:
  - 1) All devices shall be specification grade, 20-amp minimum unless otherwise indicated or required. Standard color to be white unless noted otherwise. Confirm color with Architect.
  - 2) Acceptable Manufacturers:
    - a) Hubbell
    - b) Arrow-Hart
    - c) Pass & Seymour
    - d) General Electric
    - e) Leviton
  - 3) Switches shall be quiet type, totally enclosed, back and side wired, 120-277 volt rated. Service type shall be as indicated (i.e., single pole, three-way, etc.) and in accordance with the following (Hubbell model numbers are used for reference purposes). Switches in dwelling units to be rocker type.
    - a) Single Pole: #CS120 series.
    - b) Three Way: #CS320 series.
    - c) Double Pole: #CS220 series.
  - 4) Receptacles shall be grounding type with grounding strap unless otherwise indicated, totally enclosed, back and side wired. Service type shall be as indicated (i.e., single outlet, duplex, etc.) and in accordance with the following (Hubbell model numbers are used for reference purposes, unless noted otherwise):
    - a) 2-Pole, 125-Volt, Simplex: 5261LAA (15A), 5361LAA (20A).
    - b) 2-Pole, 125-Volt, Duplex: SNAP5262LAA (15A), SNAP53626LAA (20A).
    - c) 2-Pole, 125-Volt, Duplex, Ground Fault: GFRST15SNAPLA (15A), GFRST20SNAPLA (20A).
    - d) Single-Pole, Switch with One Receptacle: RC108LA.
    - e) Weather-Resistant 125-Volt Duplex: GFWRST20LA.
  - 5) Provide NEMA standard configuration for special outlets rated above 20-amp and/or above 125-volt unless otherwise required for a particular Device plate shall be one piece with unbreakable plastic for all new single and multi-ganged devices. Color to match device color, unless noted otherwise. Where plate is replaced at existing devices to remain, provide matching cover plates.
- b. Sleeves to be Schedule 40 black steel or Schedule 80 PVC.
  - a) piece of equipment. Coordinate exact types with actual equipment provided.

8. Grounding:

- a. Main Service disconnecting means grounding:
  - 1) Make grounding and bonding connections at the building main service equipment or main disconnecting means and extend the grounding electrode conductor to the point of entrance of the metallic water service main. Make connections to the water pipe by a suitable grounding clamp. If flanged pipes are encountered, make connections with the lug bolted to the street side of the flange connection. Enclose the grounding conductor in rigid metal conduit and solidly bond the grounding conductor to the conduit at entry and exit wherever used. The

raceway for main grounding electrode conductor shall be exposed and accessible to allow for interconnection with ground conductors of all communications systems.

- 2) In addition to the grounding system indicated above, make ground connections to driven ground rods on the exterior of the building with a maximum resistance to ground of 5 OHMS under normally dry conditions. Three driven ground rods set in a triangular arrangement shall be utilized, spaced not less than 10' on centers. Make a ground connection to 20' of building footing reinforcing bars. Driven ground rods shall be located in unpaved areas only. Rods shall be fully driven with at least 2" of cover over top of rod.
9. Color of all devices and cover plates to be light almond.
10. Combination smoke and CO detectors per code. Hardwired with battery backup per code. Hush feature. Acceptable manufacturers: Kidde; First Alert.
11. Provide one (1) ceiling fan J-box per unit in bedroom. Separate control for light/fan. Location to be finalized in the field.
12. Refer to Drawings for Floor Plans, Elevations, and Mechanical/Electrical Systems Reference Plan.
13. Doorbell: Hardwired chime and button. Button at front door. Exterior doorbell button must be self-lit.
14. Light switches to be located 46" above finished floor as measured to top of rough-in box. Receptacles shall be a minimum of 18" above finished floor. See Drawings for device height where they are over a counter surface or serve an appliance.
15. Provide one (1) 220v dryer receptacle at laundry location at each dwelling unit. Breaker as required.
16. Provide one (1) 220v range receptacle at kitchen range location. Breaker as required.
17. Exhaust Fan and Fan/light Connections:
  - a. Wire main bathroom fan for continuous operation by switching the red (high speed) leg and leaving black wire (low speed) hot. At all other bathroom, all fan features wired for switch function.
  - b. Range Hood Power: Receptacle in cabinet over range hood.
18. Coordinate power to mechanical and plumbing systems, including but not limited to:
  - Gas water heater.
  - Ventilation systems listed above.
19. Appliances shall be uncrated and set in place by Contractor, and hooked up and tested:
  - a. Standard Range: Model number to be determined by Owner.
  - b. Refrigerator:
    - 1) Units: Model number to be determined by Owner.
  - c. Standard Dryer: Model number to be determined by Owner.
  - d. Standard Washer: Model number to be determined by Owner.
20. Light Fixtures:
  - a. LED Luminaires:

All lighting fixtures and lamps provided by SBH unless otherwise noted. Delivered to site by SBH in groups of 2 duplexes.

Q. DIVISION 31 - EARTHWORK

1. "Excavation" consists of removal of material encountered to subgrade elevations indicated and subsequent disposal of materials removed. The subcontractor shall be responsible for familiarizing himself with the existing site conditions. Earthwork includes the following:
  - a. Excavation and preparation of subgrade for building slabs, curbs, walks, pavements and site improvements included as part of this work.
  - b. Dewatering to keep subgrades and excavations dry.
  - c. Placement of topsoil and finish grading of lawn areas included as part of this work.
2. Soil Materials - Definitions:
  - a. Satisfactory soil materials are defined as those complying with ASTM D2487 soil classification groups GP, SW and SP. (Sand and gravel soil types).
  - b. Restricted soil materials are defined as those complying with ASTM D2487 soil classification Subbase Material: INDOT #53 graded mixture of natural gravel, natural stone, crushed gravel, crushed stone, or recycled concrete.
  - c. Backfill and Fill Materials: Soil materials free of clay, rock or gravel larger than 2" in any dimension, debris, waste, frozen materials, vegetable and other deleterious matter,
  - d. Drainage Course: Clean, free-draining granular soil containing not more than 10%, by dry weight, passing a No. 200 sieve.
  - e. Topsoil - Banked: Contractor shall clean existing topsoil suitable for reuse to remove subsoil, clay lumps, brush, grasses, weeds and other litter, and free of roots, stumps, stones larger than one inch (1") in any dimension, and other extraneous or toxic substance harmful to plant growth.
  - f. Topsoil - New: Soil shall have a defined granular or blocky structure and shall be free from non-soil material, brick and other building materials and wastes, potential sharps, hydrocarbons, plant matter, roots of perennial weeds and any other foreign matter or material or substance that would render the topsoil unsuitable for use.
  - g. groups GC, SC, ML, MH, CL, CH, OL, OH and PT. (Silts, clays, and organic soil types).
3. At building pads, perform excavation to the lines and depths indicated on the plans for foundations at each building site to limit grading to within parcel lines indicated on the Project Drawings. In cases where large rocks or tree stumps are discovered during excavation, report conditions to Architect.
4. Remove vegetation, trees, stumps, vegetation debris, "restricted" soil materials, obstructions, and deleterious materials from ground surfaces prior to placement of fill material. Items removed from building sites shall be removed from the project area and disposed of properly.
5. Contractor to be familiar with the finish grading plan for each building and export excess materials

to the soil and topsoil stockpiles in the project as designated.

6. Erosion Control: Erosion control measures installed prior to start of building construction shall be maintained. Additional erosion control silt fence shall be installed between building sites and moved as the project progresses. Each contractor shall be responsible to keep tracked vehicles and wheeled vehicles from removing soils from the project site. Use of mats and temporary gravel parking beds minimize movement of equipment from the project site to minimize carrying soils into roadway and roadway construction areas. Where storm drain inlets exist adjacent to a building, maintain inlet protection as shown on project details. Comply with IDEM requirements, with weekly reports by GC.
7. Structure Excavation:
  - a. Excavate to the depth indicated on the Drawings unless unsatisfactory conditions are encountered. If such conditions occur, the excavation shall be carried to a depth where satisfactory soil conditions are covered which would provide suitable support for construction. Such additional depth shall be filled with compacted granular fill. The width of such fill shall be, at minimum, twice the footing width.
  - b. The trenches for column footings, foundations, areas, pits, etc., are to be dug and formed, level, square and to full dimensions and depths indicated on plans. Excavate to a point not less than 1'-6" outside of exterior foundation line to permit erection of forms.
  - c. Grade all floors, walks, and pavement areas to  $\pm 1/2$ " of finish subgrade.
  - d. Shoring and Bracing: All excavations shall be properly shored as required to prevent cave-in. Excavation walls should be sloped, shielded or shored in accordance with current Occupational Safety and Health Administration (OSHA) guidelines and requirements.
8. Prevent surface water and ground water from entering excavations and from ponding on prepared subgrades. Reroute surface water away from excavated areas to avoid water accumulating within excavations.
9. Dewatering: Where, during construction, water accumulates at construction site, coordinate with the Owner a location for dewatering operations to occur. In general, water from dewatering pumps shall be directed to adjacent storm water ponds or sediment removal prior to entering storm system.
10. Backfill excavations as promptly as work permits, but not until acceptance of construction below finish grade including:
  - a. Inspections, testing, approval and recording locations of underground utilities.
  - b. Removal of concrete formwork.
  - c. Removal of trash, rubbish and debris.
  - d. Installation of drainage tile where shown on the Project Drawings.
11. Slabs on Grade: At building slab on grade, provide prepared subgrade of clean native sand and gravel, free of organic matter. Compacted to uniform density and prepare for specified vapor barrier. See Project Drawings for required thickness of subgrade material.
12. Rough Grading: Work grades to provide for positive surface drainage. Uniformly grade areas within limits of grading under this section, including adjacent transition areas. Smooth finished surface within specified tolerances, compact with uniform levels or slopes between points where elevations are indicated, or between such points and existing grades. Grade areas adjacent to building lines to drain away from structures and to prevent ponding.

13. Finish Grading: Prior to placement of concrete walks, remove all debris, trash, roots, branches and stones larger than 2" from topsoil materials. Place topsoil around building and correct settlement irregularities to within 1" of final grade. Do not place organic materials where walks are to be poured.
14. Final Grading: Rake site to remove debris, stones, roots, etc., to a minimum depth of three inches (3") in all lawn and planting areas, unless otherwise noted. Remove debris and fine grade smooth. Add topsoil as required to provide base for lawn seeding.
15. Protect newly graded areas from traffic and erosion. Keep free of trash and debris. Repair and reestablish grades to specified tolerances where completed or partially completed surfaces become eroded, rutted, settled, or where they lose compaction due to subsequent construction operations or weather conditions.
16. Remove waste materials, including excess soils, excess topsoil that cannot be spread to levels indicated, unacceptable excavated material, trash and debris, and dispose off-site in a legal manner.

R. DIVISION 32 - EXTERIOR IMPROVEMENTS

1. Landscaping:
  - a. Power rake building site and remove remaining surface debris from the project.
  - b. Provide additional topsoil around each building to establish final grade.
  - c. Grass Seed: Grass seed to be general purpose sun shade/sun blend. Grass seed to be planted after September 1, 2023.
  - d. Watering Newly Planted Areas: Water seeded areas at initial planting and at regular intervals following until individual building site is turned over to the Owner. Owner is responsible for watering lawn areas thereafter.
  - e. Lawn Repair: At time of building turnover to the Owner, lawn areas shall be inspected for initial growth and coverage. Repair damaged areas and reseed (spot seed) areas where required.
  - f. Provide vinyl edging, landscape fabric, mulch and landscape planting as indicated on the Project Drawings at each site. See Site Landscape Plans for dimensions and layout of landscape beds.
2. Splash Blocks and Downspout Connections: At downspouts, install pre-cast concrete splash blocks. Set each splash block firmly into soil materials and set to direct water away from building foundation. Where downspout connections are indicated on Project Drawings, provide transition caps at each downspout and with no more than 6" of drain tile extension.
3. Curbs and Walks: Shall be as noted on Drawings. Concrete materials shall have a minimum compressive strength of 3,500 psi. Comply with City of South Bend requirements for size, dimensions, joints and finish. Obtain permits as necessary. Coordinate installation with work being performed by the City of South Bend.

S. DIVISION 33 - UTILITIES

1. Existing Utilities: Locate existing underground utilities in areas of work. If utilities are to remain in place, provide adequate means of support and protection during earthwork operations. Should uncharted, or incorrectly charted, piping or other utilities be encountered during

excavation, consult SBH immediately for directions. Locate the City-provided sewer lateral and adjust sanitary layout to provide the most efficient route to the connection.

2. Utilities:

- a. Water: At each duplex, provide new 1" type K copper water line from stop valve at property line to each building. Route water line under footing to future meter location. Leave 12" vertical extending above slab and cap line. Provide pressure test in accordance with City of South Bend Water Department. Provide sleeve where copper piping passes through foundation or concrete slab per code.
- b. Sanitary: Extend 6" SDR35 PVC from existing lateral for each building as shown on plumbing drawings. Provide a two-way cleanout where piping passes through foundation wall. All cleanout caps in lawn areas to be inverted type. Mark cleanouts to protect from damage. All cleanouts, including the one at the City-provided lateral, shall be lowered to finish grade.

**End of Section**