



March 14, 2022

RE: 421 Sherman - Request for Proposals (RFP)

Attention bidders:

The South Bend Heritage Foundation is pleased to release the following single family home for bid. This project will construct one new single family homes beginning Spring of 2022 at 421 Sherman Street in South Bend, IN.

Please note that this project has very specific time, contract, insurance, and billing requirements that some bidders may not be familiar with. Read the all the RFP documents carefully and do not hesitate to ask any questions you may have.

Bidder registration is required to SBH by March 30, 2022. Bid proposals on this package are due to SBH by 3:00PM Wednesday April 6, 2022. Please carefully review RFP package for further information. Good luck.

Cordially,

Patrick Lynch
patlynch@sbheritage.org
574.286.0816

RFP Document List

All documents listed below are available in .pdf format on the South Bend Heritage website.

Please go to <http://sbheritage.org/projects-blog/contractors/>

- RFP Invitation to bid 03-14-2022
- Project Manual 03-14-2022
 - RFP Invitation to bid
 - Specifications
 - **A** through **N** bid package descriptions
 - Bid form (copy as needed for each bid package)
 - Insurance minimums
 - Contractor references form
- Drawing Set dated 03-14-2022

Specifications for: 421 Sherman Street
Issued with RFP: March 14, 2022
Revised:

DIVISION 0 – Bidding and Contract Requirements

1. This specification, dated March 14, 2022 or as later revised, supersedes and replaces all prior specifications for this project.
2. Bids will be due on **Wednesday April 6, 2022** at the SBH offices by 3:00PM. (Received via mail, faxed, emailed, or dropped off by this time.) SBH offices are located at 803 Lincoln Way West, South Bend, IN 46616. Bids are to the attention of Pat Lynch at 574.286.0816.
3. Bids not utilizing the attached Bid Form will not be accepted. Additional materials may be submitted. Voluntary alternates submitted in addition to the primary bid documents will be considered. One bid form per bid package.
4. Bidder References
Provide names and contact information for three prior clients in which your company demonstrated an ability to deliver a project under a demanding schedule or otherwise met your client's schedule expectations. One criterion for determining bidder responsiveness will be a demonstrated ability to deliver projects on schedule.
5. Bidder Registration
All bidders must notify SBH of their intention to bid by Wednesday, March 30, 2022. Project notices and addenda notices will be emailed to registered bidders only. Contractors who received an RFP invitation to bid emailed from SBH are considered pre-registered.
6. Full and complete contractor markup on any positive value change orders to be disclosed on the Bid Form.
7. Bid the work according to the RFP documents. If you or your subs have questions about elements of the work please contact SBH. If information is lacking SBH will issue new guidelines (Addendums) to all Bidders.
8. Voluntary Alternates
Bidders may submit voluntary alternates. Voluntary alternates will only be considered if bidder has first provided a bid for the work as specified. List voluntary alternates on a separate form or additional copy of the bid form. Number and clearly describe the scope of each voluntary alternate.
SBH will also consider a voluntary alternate in which two or more separate bid packages are linked for a combined bid amount different than the sum of the separate bid amounts.
9. Approved Equal (Substitutions)
No substitutions of specified products are permitted without written approval from SBH.

10. Contract between General Contractor and Subcontractor.
The successful bidders will be expected to execute AIA Document A401–2007, Standard Form of Agreement Between Contractor and Subcontractor or an equivalent SBH agreement. Review copies of this agreement are available from SBH.
11. Applications for Payment
Draw requests will be made from the Contractor to the Owner at no less than 30 day intervals utilizing AIA G702 and G703 forms. Payment will be made only for work in place at time of the application for payment. Materials purchased and stored may be billed if covered against loss by a certificate of insurance acceptable to SBH.
Monthly applications are due to SBHF on the 25th of each month. Payment may be expected from SBH in not less than 30 days or more than 45 days.
- ~~12. Lien Waives
Partial conditional lien waivers are required for each application for payment. SBH prefers that partial lien waivers are submitted in the amount equal to the accompanying draw and conditional upon payment of the draw amount.
A final lien waiver is required at last application for payment. Sub-Contractor lien waivers are not required. However, the Contractor will promptly provide written documentation of Sub-Contractor payment if requested by SBH.~~
13. Notice to Proceed
No billable work or commitments of any sort are to begin on the project until after the Contractor has received a written notice to proceed from the Owner. Notice to proceed will be issued to all contractors at the same time at least 1 week prior to the start of construction.
14. Schedule for Construction
See division 1
15. Retainage
Contract will be executed with 5% retainage on each sub-contractor draw. Retainage will be released upon Substantial Completion of the contract minus an amount ascribed to specific punch list items until those items are completed and as otherwise described in AIA A201.
16. Prevailing wage and Certified Payrolls
This project does not fall under prevailing wage guidelines. Certified payrolls are not required.
17. Insurance
Certificates of insurance will be required prior to start of the Work. Refer to attached minimum limits of liability. South Bend Heritage Foundation, Inc. shall be named as additional insured under the Contractors' Comprehensive General Liability Policy.
18. Not used

19. MBE and WBE

South Bend Heritage is committed to minority and women's business enterprise participation in this project.

As a requirement for bidding on this Project, all bidders shall provide written documentation evidencing the bidder's good faith efforts to further South Bend Heritage Foundation's desire to facilitate local worker and MBE/WBE participation in this project. Such documentation shall include a listing of all MBE/WBE's contacted including: (1) the name and address of the MBE/WBE; (2) the type of contact made (i.e. telephone, written solicitation, etc.); (3) the date of the contact; (4) the nature or type of services or goods requested; and (5) the result of the contact.

Responsive bidders shall include this written evidence of their good faith efforts including copies of outreach and copies of email exchanges inviting and receiving quotes or other responses from MBE/WBE firms or other documentations of efforts to encourage and secure competitive quotes from MBE/WBE and local businesses to be included in the benefits of building this project. Written documentation of letters of introduction, invitations to forging majority/minority strategic alliances for capacity building including but not limited to mentoring, extensions of assistance on payroll, insurance, bonding, line of credit, technical skills or business skills will be accepted as further evidence of good faith effort.

All bidders are actively encouraged to reach out to the MBE/WBE firms in St. Joseph County and make real good faith efforts to forge constructive and lasting business partnerships.

20. Copies of the winning bid forms will be available from the Owner after the contract is awarded and construction has commenced.

DIVISION 1 – GENERAL

1. Summary of the Work

Refer to the individual bid package descriptions in a separate document. These bid packages are not specifications. They merely divide the work into biddable portions and refer to the specifications. The scope of work described in each bid package does not limit the contractors' responsibility to understand the entire project and the required coordination of their work with other trades.

There is 1 house to be constructed:

Address	Parcel ID #	House type		
421 Sherman Avenue	018-1034-1489	4 bedroom + Garage		

2. Printed documents

To order prints of the drawings (full or half size) and associated RFP documents contact ARC (previously South Bend Drafting Supply), 1303 Northside Blvd. South Bend, IN. 574-287-2944. Interested bidders are responsible for purchasing and picking up bid packages from South Bend Drafting Supply.

3. Coordination & Precedence of the Contract Documents

The documents included in the contract are intended to be complementary and to describe a complete work. In case of a difference between drawings and specifications, the specifications shall govern.

4. Means and Methods

The drawings are meant to indicate the general scope of the bid package as related to the site plan, floor/roof plans, and elevations, and are not intended to be fully detailed construction documents. Contractor is responsible for all construction means and methods. This wood frame residential structure and all parts thereof, shall be designed and constructed in strict compliance with the Indiana Residential Code 2005 (IRC) to safely support all loads without exceeding the allowable stresses for materials of construction in structural members and connections. This includes concrete foundation walls/footings, floor, wall and roof framing, beams, lintels, and wind/lateral loading.

5. South Bend Heritage reserves the right to reject any or all bids, and to waive any irregularities in bidding and to make an award in the best interest of the South Bend Heritage Foundation and the City of South Bend.

6. Minor Changes

The Contractor will advise the Owner of minor changes in the Work not involving an adjustment to Contract Sum/Price or Contract Time.

7. Requests for Information (RFI)

The contractor may submit a request for information to SBH to seek clarifications or resolution to questions that arise during the course of the Work that are not covered in the Construction documents. The SBH will respond within 5 days.

8. Architects Supplemental Instructions (ASI)

The Architect or SBH may issue supplemental instructions which include a detailed description of a clarification or proposed change with supplementary or revised Drawings and specifications. If the ASI results in a change to the Contract Sum and/or Contract Time the Contractor will prepare and submit an estimate within 10 days.

9. Potential Change Orders (PCO) Change Orders (CO)

The Contractor may propose a change by submitting a PCO request for change to the SBH, describing the proposed change and its full effect on the Work, with a statement describing the reason for the change, and the effect on the Contract Sum and Contract Time with full documentation.

10. Permits

The *Utility verification Form* from the SB BOPW will be coordinated and paid for by the Owner.

The street cut permit; occupancy permit (if required); water tap fee; will be coordinated and paid for by the Plumbing subcontractor

The Sewer tap fee if required to be paid by contractor installing the lateral. (Base bid assumes that a usable existing lateral will be found onsite)

The Sewer excavation fee (for excavation within the property line) to be paid by contractor installing the lateral only if required by the BOPW. It is the contractor's responsibility to determine if this fee applies for the base bid condition.

11. Schedule

Construction is expected to begin approximately Spring 2022. Notice to proceed will be issued to all contractors at least 1 week prior to start date. Sub-contractors may not begin work until satisfaction of all pre construction requirements. The Schedule is of the essence for this project. Refer to the schedules for each bid package as outlined in the bid package descriptions. Schedules are provided for bidding and general coordination purposes. Contractors will be notified by SBH if adjustments to the schedule are made.

12. Adverse Weather

NA

13. Bidder References

Provide names and contact information for three prior clients in which your company demonstrated an ability to deliver a project under a demanding schedule or otherwise met your client's schedule expectations. One criterion for determining bidder responsiveness will be a demonstrated ability to deliver projects on schedule.

14. Meetings & Coordination

Standard Pre-Construction Meeting: date and agenda to be determined.

The following shall be provided by each sub-contractor in advance of the meeting:

- Draft schedule of values on AIA G702/G703. (Excel document from SBH)

SBH is responsible for the coordination of schedules, submittals, and the Work to assure efficient and orderly sequence of installation of interdependent construction elements.

15. Energy Code Compliance

This project will meet the energy code using the performance path.

16. Submittals and/or shop drawings

Submittals from Contractors to Architect or Owner and SBH are required for the following:

- Truss and framing package showing primary structural calculations and loading.
- Panelized wall system if used and other primary structural elements
- Windows – fabricator submittal / shop drawings
- Exterior doors ~~and storm doors~~ – mnfr. submittal
- Interior doors – mnfr. submittal
- Door hardware – mnfr. submittal
- Gypsum wallboard
- Cabinetry layout – vendor drawing based on field verified dimensions
- All exterior finish materials and colors incl. colored flashing – material sample with color applied
- Roofing shingle and underlayment – physical sample from manufacturers
- All interior finish trim materials and colors – finish mnfr. samples
- Floor finishes – carpet, pad, vinyl, underlayment
- HVAC heat/cooling load calculations. Manual J.
- All HVAC equipment – mnfr. submittals
- All Plumbing equipment and fixtures – mnfr. submittals. Include left or right hand qty.
- All required close out documents and OEM manuals

Submit (3) copies of paperwork and (1) physical sample (if required above) for approval. SBH will respond within three days with approval, conditional approval, or rejection for revision and re-submittal. PDF emailed submittals in lieu of paper submittals are acceptable. Email submittals to patlynch@sbheritage.org.

17. Schedule of Alternates

None

18. Allowances

None

19. Construction Facilities

SBH shall maintain at least one complete full size and bound set of drawings and specifications at the jobsite for all sub-contractors to reference and make as-built notations. Temporary Electric Service installed by EC. AEP account for temp. power is the responsibility of SBH.

Dumpsters provided and paid by SBH.

Port-a-Potty shall be provided and maintained on site by SBH.

20. Onsite Storage

To the greatest extent possible, this project will operate with “just in time” delivery of all materials. Staging of materials onsite outside of the period scheduled for that trade is not permitted unless pre-arranged with SBH and in contractor provided storage container. Storage of material for current use in structures already completed is not permitted. Staging

of materials for more than one group at a time is not permitted unless pre-arranged with SBH and in contractor provided storage container.

21. Safety

It is SBH's responsibility to maintain and enforce an environment of safe work practices at the job site.

22. Cutting, Notching, and Drilling

Structural floor members shall not be cut, bored or notched in excess of the limitations specified in section 502.8 of the Indiana Residential Code.

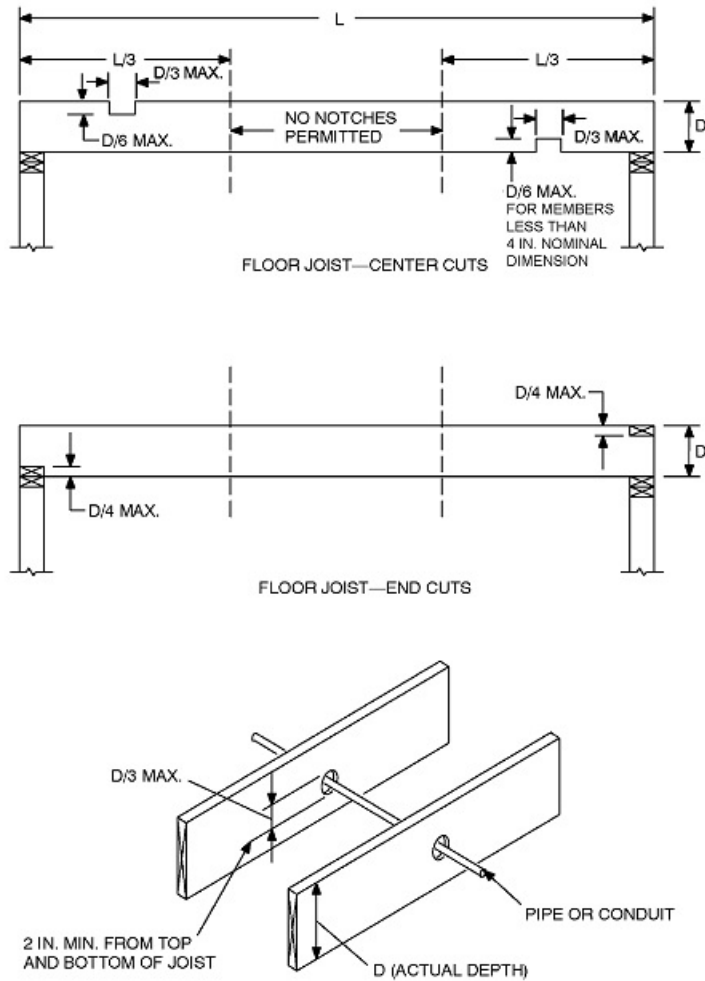

FIGURE R502.8 CUTTING, NOTCHING AND DRILLING

23. Job-site debris and cleaning

Premises will be left each day by each subcontractor broom clean. SBH is responsible to enforce a clean and tidy job site.

24. Temporary Controls

Construction Materials shall be stored off the ground and covered to avoid absorption of moisture and damage.

Mechanical ducts shall be sealed during construction.

25. Construction Waste Management

All dumpsters by SBH.

Jobsite to be maintained in a clean and orderly condition. Each contractor is generally responsible for depositing debris generated by their work into the SBH provided dumpster.

26. Contract Closeout

- As defined in Construction Agreement
- Punch list procedures: Contractors shall walk through each unit with SBH to determine the punch list and which items shall be monetized on the final punch list.
- Operation and maintenance manuals of all systems shall be required.

DIVISION 2 – SITEWORK

1. "Excavation" consists of removal of material encountered to subgrade elevations indicated and subsequent disposal of materials removed. The Contractor shall be responsible for familiarizing himself with the existing site conditions. Earthwork includes the following:
 - a. Excavation and preparation of subgrade for building slabs, curbs, walks, pavements and site improvements included as part of this work.
 - b. Dewatering to keep subgrades and excavations dry.
 - c. Placement of topsoil and finish grading of lawn areas included as part of this work.
2. Existing Utilities:

Locate existing underground utilities in areas of work. If utilities are to remain in place, provide adequate means of support and protection during earthwork operations. Should uncharted, or incorrectly charted, piping or other utilities be encountered during excavation, consult SBH immediately for directions. Locate and preserve the existing (previously abandoned) clay sewer lateral at each site.
3. Soil Materials - definitions
 - a. Satisfactory soil materials are defined as those complying with ASTM D2487 soil classification groups GP, SW and SP. (Sand and gravel soil types).
 - b. Restricted soil materials are defined as those complying with ASTM D2487 soil classification groups GC, SC, ML, MH, CL, CH, OL, OH and PT. (Silts, clays and organic soil types).
 - c. Subbase Material: #53 graded mixture of natural gravel, natural stone, crushed gravel, crushed stone, or recycled concrete.
 - d. Backfill and Fill Materials: Soil materials free of clay, rock or gravel larger than 2" in any dimension, debris, waste, frozen materials, vegetable and other deleterious matter,
 - e. Drainage Course: Clean, free-draining granular soil containing not more than 10%, by dry weight, passing a No. 200 sieve.
 - f. Topsoil - banked: Contractor shall clean existing topsoil suitable for reuse to remove subsoil, clay lumps, brush, grasses, weeds and other litter, and free of roots, stumps, stones larger than one inch (1") in any dimension, and other extraneous or toxic substance harmful to plant growth.
 - g. Topsoil – new: soil shall have a defined granular or blocky structure and shall be free from non-soil material, brick and other building materials and wastes, potential sharps, hydrocarbons, plant matter, roots of perennial weeds and any other foreign matter or material or substance that would render the topsoil unsuitable for use.
4. Perform excavation to the lines and depths indicated on the plans. Excavate within grading limits to the lines and elevations indicated on the drawings. Notify SBH if excessive concrete or other unexpected materials are found during excavation.
5. Remove vegetation, trees, stumps, vegetation, debris, "restricted" soil materials, obstructions, and deleterious materials from ground surface prior to placement of fills. Plow, strip, or break-up surfaces so that fill material will bond with existing surface.
6. Erosion control

At no time allow water/sediment runoff or soils to spill onto adjacent properties. SC to install and maintain necessary erosion control methods. At minimum SC to install silt fence at property line adjacent to Hill Street.

7. Site Improvements: Excavate for exterior concrete slabs, piers, steps, curbs, sidewalks, pavements and areas etc. to the required depths.
8. Structure Excavation:
 - a. Excavate to the depth indicated on the drawings unless soft spots or other unsatisfactory conditions are encountered. If such conditions occur, the excavation shall be carried to a depth where satisfactory soil conditions may be obtained to provide suitable support for construction required. Such additional depth or excavation shall be filled with compacted granular fill.
 - b. The trenches for column footings, foundations, areas, pits, etc. are to be dug and formed, level, square and to full dimensions and depths indicated on plans. Excavate to a point not less than 1'-6" outside of exterior foundation line to permit erection of forms.
 - c. Grade all floor, walk, and pavement areas to + 1/2" of finish subgrade.
 - d. Shoring and Bracing: All excavations shall be properly shored as required to prevent cave-in. Excavation walls should be sloped, shielded or shored in accordance with current Occupational Safety and Health Administration (OSHA) guidelines and requirements.
9. Prevent surface water and ground water from entering excavations, from ponding on prepared subgrades, and from flooding Project site and surrounding area.
10. Protect subgrades from softening, undermining, washout, and damage by rain or water accumulation. Reroute surface water runoff away from excavated areas. Do not allow water to accumulate in excavations.
11. Utilities

Water - FC provide new 1" type K copper water line from new tap at city main to new basement. Route water line under footing to future meter location and leave minimum 12" vertical extending above slab. Coordinate pressure test with city of South Bend as required. Cap line in basement for hand-off to PC. Code compliant sleeve where copper passes through foundation or concrete slab to protect from abrasion per code.

Sanitary - During excavation, identify existing clay tile sewer lateral that used to serve that lot. Excavate existing sewer lateral to a point near the existing city sidewalk. Cut cleanly and provide a Fernco fitting and 4" PVC lateral to the new basement. Run new lateral under the footing or through the foundation wall via sleeve. Provide vertical cleanout at foundation wall and another at Fernco fitting near city sidewalk. All clean-out caps in lawn areas to be inverted type. Mark cleanouts to protect from damage.

Site contractor is responsible for setting water valve cap to finish grade.
12. Backfill excavations as promptly as work permits, but not until acceptance of construction below finish grade including:
 - a. Inspections, testing, approval and recording locations of underground utilities.
 - b. Removal of concrete formwork.
 - c. Removal of trash, rubbish and debris.
 - d. Drainage tile where specified.
13. Under slabs on grade

At basement slabs and detached garage slabs provide prepared subgrade of clean native sand & gravel, free of organic matter. Compacted to uniform density.

14. Rough Grading: Work grades to provide for positive surface drainage. Uniformly grade areas within limits of grading under this section, including adjacent transition areas. Smooth finished surface within specified tolerances, compact with uniform levels or slopes between points where elevations are indicated, or between such points and existing grades. Grade areas adjacent to building lines to drain away from structures and to prevent ponding.
15. Finish Grading: Prior to placement of concrete walks, clean subgrade of all debris, trash, roots, branches and stones larger than 2". Place banked topsoil around building and correct and settlement or irregularities to within 2" of final grade. Do not place organic materials where walks are to be poured.
16. Final Grading: "Harley-rake" site to remove debris, stones, roots, etc. to a minimum depth of three (3") inches and a maximum of four (4") inches in all lawn and planting areas, unless otherwise noted. Remove debris and fine grade smooth. Install 6 cu/yds clean topsoil around structure and distributed as otherwise required to establish final grade and provide a good base for grass seed. Include tree lawn as required.
17. Protect newly graded areas from traffic and erosion. Keep free of trash and debris. Repair and reestablish grades to specified tolerances where completed or partially completed surfaces become eroded, rutted, settled, or where they lose compaction due to subsequent construction operations or weather conditions.
18. Remove waste materials, including excess soils, excess topsoil that cannot be spread to levels indicated, unacceptable excavated material, trash and debris, and dispose off-site in a legal manner.
19. Landscaping

Power rake lot "Harley rake" and remove remaining surface debris from site. Broken concrete, bricks, and debris larger than 3" is to be removed from the top 3"-4" of the site..

Assume each lot will require 2" additional topsoil in a 15' zone around each house to establish final landscape grade.

Grass seed. Grass seed to be general purpose shade/sun blend. Grass seed to be planted after September 1st, 2016.

Watering seed – water seed at initial planting. SBH is responsible for watering seed thereafter.

Provide vinyl edging, landscape fabric, mulch; (8) 1-gallon shrubs;(4) 5-gallon shrubs around each front porch and approximately 5' around each side. Bed to be approximately 36"-48" deep from face of porch to vinyl edging.

DIVISION 3 – CONCRETE

1. All exterior concrete for walks, step, pads, and driveways shall be min. 4,000psi, max. 4" slump, and limestone aggregate. Concrete placed in the city right of way to be per BOPW specifications.
2. All footing and foundation wall concrete shall be min. 3,000psi, max. 4" slump, and limestone aggregate.

3. Establish the top of foundation wall above finish grade approx. 18" above finish grade. Finish grade is defined as a point 8" above nearest city sidewalk elevation and slopes away from foundation. Add height of any existing berm along city sidewalk to top of wall height. At detached garage, top of slab to be calculated such that driveway slope is min. 2% up from alley elevation.
4. Foundation wall for basement to be 8" thick x 8' tall reinforced concrete walls.
5. Detached garage foundations to be monolithic slab on grade.
6. Reinforcing bar at all foundations per IRC.
7. FC will install anchor bolts within 12" of each corner, either side of doors, and max. 6' OC.
8. Install (1) 6" diameter sched. 40 PVC sleeve and cap through each basement floor slab for future radon system. Locate toward rear corner of structure.
9. Provide footer drain to sump.
10. Footer drain: 4" diam. HDPE flex perforated pipe in fabric sleeve at basement perimeter. Route to separate min. 20 gallon sump pit in basement. Provide pit and cover. Pump by PC.
11. Sanitary lateral and water utility line from city main to be coordinated as required. FC is responsible to locate these lines in the basement away from any interior stairways or landings.
12. Under-slab plumbing to be coordinated with PC where occurs. .
13. Detached garage slab: 4" s.o.g. over native sand cleaned of any organic materials and plate compacted.
14. Driveway shall not exceed 2% slope.
15. Existing curbs and city sidewalks to be protected from damage unless cutting is required for utility work. Heavy equipment and trucks should enter and exit each lot from the alley! Contractors who unnecessarily damage city sidewalks or curbs may be held responsible for repair.
16. Basement slabs: 4" s.o.g. over 6 mil visqueen vapor retarder over native sand cleaned of an organic materials and plate compacted.
17. At detached garage aprons: flatwork to be 3000 psi concrete and sloped toward alley right of way. Dimensions per plans.
18. Damp-proofing: refer to division 7.
19. Porch deck and steps to be poured concrete. Refer to plans.
20. Control joints for all slabs on grade – saw cut control joints 25% of slab depth and spaced between 8' min. and 12' max.

DIVISION 4 – MASONRY

NA

DIVISION 5 – METALS

1. Fasteners and connections: per details and specifications. Simpson Strong Tie (SST) or approved equal.
2. Steel rebar and reinforcing mesh to meet or exceed IRC 2005 requirements.
3. Steel beam in basement or dimensional lumber equal per framing spec.
4. Aluminum flashing per drawings. .027 minimum thickness.

5. Steel posts in basement located per plans. Posts to be standard steel pipe column. Size per field condition and to meet or exceed IRC 2005 requirements. Bolted connections at top. Tapcon acceptable at base. Secure cap and base at all attachment holes.
6. Window egress well and protective top grate by FC. Corrugated steel area well – Monarch Stif Back II – SB11 49 36 60 egress.

DIVISION 6 – WOOD AND PLASTICS

1. Rough carpentry dimensional lumber shall be No.2 yellow pine or fir; all lumber shall be straight and free from defects. All lumber in contact with concrete shall be treated. All exterior wall studs to be 2x4 and 96 5/8" precut type u.o.n. Wall framing may be SPF #2. All joists and beam members to be SYP #1.
2. Panelization and stick-framing are both acceptable base bid approaches. Please note your chose approach on the bid form. FC will install anchor bolts within 12 of each corner, either side of doors, and max. 6' OC. CC responsible for coordination or installation of additional sill plate anchors as required to meet code.
3. All base bid roof deck and exterior wall sheathing is 7/16" OSB. Roof deck with 'H' panel edge clips.
4. 1/2" fire resistant plywood at all electrical panels. 4'x4' sheet at each house in group A through F. Install after insulation where occurs.
2. All trusses for residential structures to be designed with 12" energy heels. Detached garage trusses to have conventional heels.
3. Provide and install 2x blocking. CC contractor shall inspect Drawings for all cabinetry, shelves, handrails, towel bars, toilet paper holder, grab bars, mirrors, shower rods, etc. and provide 2x blocking as required. 2x blocking to be provided in all standard unit bathrooms to allow future addition of shower and toilet grab bars per Fair Housing Act. Provide blocking to secure fiberglass shower edges; grab-bars, and add'l framing as required to secure any half walls for lateral stability.
4. Laundry wet wall
At any laundry wet wall located on an exterior wall, construct a 2x4 x 48" tall half-wall inside of the exterior wall framing for all laundry mechanical rough ins. 1x trim cap and apron. This framing to be separated from the exterior wall framing with continuous layer of 1/2" OSB sheathing.
5. Soffits
~~Framed soffits may be required in the following areas and are subject to minor field revision to accommodate variances in the MEP rough ins:~~
 - a. ~~Kitchen ceiling along bearing wall to cover hvac and pb rough in.~~
 - b. ~~Around vortical duct(s) at corners of living room or kitchen.~~~~Soffits are to be as small and tight to MEP rough in as possible. Maintain 1" clearance at HVAC supply ducts.~~
Soffits are not otherwise required over kitchen cabinetry.
6. Cabinets & tops for Kitchen and Bathrooms
SBHF will provide cabinetry and tops. Cabinetry installation by CC. Tops installed by SBH.

Cabinetry pulls: none u.o.n. (top and bottom door edges have 15 degree reverse bevel)

Int. Trim Carpenter to provide mounting blocks for range hood as required at wall cabinet over range.

Provide shop drawings, product data and samples for Owner or Architect approval.

7. Medicine cabinet/mirror in full bathrooms:

SBHF will provide recessed med. cabinet for any full bath off a hallway. Mirror for other bathrooms. installed by CC.

8. Install the following accessories shown on enlarged plans in each bathroom:

- 1x Towel bar (24") in ½ and ¾ bathrooms.
- 2x Towel bars (24") in full bathrooms
- 1x Towel hook
- 1x Toilet paper holder
- 24x36 mirror at all ¾ and ½ baths. Mount 40" max. aff.
- Shower rod at each tub/shower and ADA xfer shower unit. Single, straight rod with screw attachment. 72" AFF.

Color of bathroom accessories to be brushed nickel. Provide shop drawings, product data and samples for Owner or Architect approval.

9. Interior Trim

Interior door and window casing trim is 11/16" x 3.5" colonial factory PFJ. "Picture frame" each window and door opening.

Baseboard is 9/16" x 5.25" colonial base factory PFJ. Cope all inside corners.

1/2" x ¾" base-shoe at all non-carpeted floor edges.

1x skirt trim at all stairways including basement. Painted. Basement stairs are 2x12 and provided in package B-1.

Interior doors are pre-hung and primed. Refer to Division 8.

10. Shelves

All linen and closet shelves to be 1x12 solid wood or prefinished melamine material.

All laundry room shelves to be 12" deep wire system.

1x cap fabricated from shelf material at any laundry area half walls. Painted.

Cleats and metal shelf support brackets secured to framing. Brackets 48" OC maximum.

Hanging rods to be 1-1/4" dia. wooden dowel.

11. Stairs where occurs:

- a. from First Floor to Second Floor shall be finished as follows:
 - Handrail – LJ6010, poplar, stain/polyurethane finish
 - Half wall cap where occurs – 5/4 oak, Stain/polyurethane finish to match treads. Eased edges.
 - Stair treads and risers to be carpeted.
- b. Open basement stair:
 - Stairway balustrade to be open with oak newel, balusters, and stained rail.
 - Handrail to be LJ6010 or equal. 1x skirt boards. To be carpeted.
- c. Enclosed basement stair:
 - 2x treads with 1x risers. 1x skirt boards. Painted.

12. Exterior Porch Columns: Fiber-reinforced polymer composite; HB&G PERMA Cast® 14"x12" x 9' tall square tapered columns with corresponding cap/base; prime and finish paint per manufacturer's requirements. Provide shop drawings, product data and samples for Owner or Architect approval.
13. Exterior Porch Railing: Heng Industries Extreme Vinyl – Vinyl railing system or approved equal; Style: T-Bird with aluminum reinforced top and bottom rails; 4"x4" support post with traditional top cap; 1-3/8"x1-3/8" spindles; Color: per exterior finish schedule. Factory modify balustrade height to 30" from top of concrete deck to top of horizontal rail. Stair handrail remains as required for code compliance.
Include handrail at one side of rear stoop at all houses. Rail to match front porch system. Submittal required. Provide product data and samples for Owner or Architect approval.
Manufacturer: Heng Industries, USA, Elkhart, IN 574-295-1200. (office)
14. Soffits
Aluminum panel. Vented at house. Garage soffits are NOT vented. Color per schedule.
15. Front porch soffit
Beaded wood panels. Stained.
16. Exterior Siding: Certaineed Monogram .046 double 4 vinyl siding and associated accessory trims, starter strips, j-channel, and incidental materials as otherwise required for a complete job. Colors per exterior finish color schedule.
17. Exterior Trim: LP SmartSide® - 540 Series reversible trim - smooth surface finish; Pre-Primed – Site finish paint; see Drawings for sizes and locations. Siding & trim contractor to coordinate trim blocking required for mechanical penetrations through siding including but not limited to: dryer vent, furnace vents, electric meter base, elec. service entrance, sill cocks.
Paint all cut ends prior to installation.

18. Exterior finish schedule:

Address	Roof color	Vinyl lap siding (lower)	Vinyl lap siding (upper)	Garage siding	Corner trim	Painted Trim	Porch railing system	Gutters & alum. flashing	Soffit & porch ceiling	Entry door exterior color
421 Sherman	Weathered Wood	Linen double 4	Charcoal triple 3	Linen double 4	5/4 wd corners	White*	white	white	white	SW7588
	GAF	matching vinyl corners	Wood corners		At lower siding only					"show stopper"

DIVISION 7 – THERMAL AND MOISTURE PROTECTION

1. Damp-proofing concrete foundation walls.
Tremco Polypro spray-applied damp-proofing or approved equal.
Apply per mnfr. specifications for a 16 mil (cured) thickness.
Apply from footing to calculated finish grade. Do not apply above finish grade.
Apply before footer drain tile is placed.
2. Cellulose Insulation: see drawings for insulation types, R-values, and locations. Wet blow walls full depth.. Loose blow attics to be R38.
3. Fiberglass Insulation: R13 at basement stud wall w/ FR poly scrim over. R21 at box sill and second floor rim joist over spray foam; eaves as required. Fiberglass shall not be used in lieu or as an equivalent for cellulose.
4. PSK poly scrim: at basements provide continuous fire resistant white film over basement exterior wall framing to meet code fire resistance requirements. Lamtec WMP-10 or equivalent.
5. Refer to division 8 for attic scuttle insulation.
6. Spray foam – closed cell
 - a. Box sill seal – at structures with basements: 1” closed cell 2 PCF spray foam from top face of fndn wall to underside of floor deck & min. (R21 unfaced fiberglass batts over)
 - b. Rim joist seal – at two story structures only, between first and second floor – 1” closed cell 2 PCF spray foam from top of first flr top plate to underside of floor deck above. & min. (R21 unfaced fiberglass batts over)
 - c. Behind all exterior wall electrical boxes – low expansion closed cell foam to seal box.
7. Low expansion foam – at windows and doors perimeters. Foam bead to be continuous.
8. Dimensional Fiberglass Asphalt Roof Shingles & underlayment
Acceptable manufacturers: Owen Corning® Oakridge II (30yr); GAF Timberline “Natural Shadow”; approved equal.
Colors per schedule are chosen from the GAF line. Assume similar colors for other manufactures. Submittal required.
Include matching starter strip, ridge cap.
Install per mnfr. specifications over underlayment per drawings.

See Drawings for roof deck details including minimum .027 pre-finished flashing/drips/fascia; continuous ridge vent; and self adhered ice/water shield. Install ice/water shield at roof eaves only.
9. Ice & Water Shield
At eaves and as otherwise required by code.
Acceptable manufacturers: GAF “Stormguard”; Owens Corning “Weatherlock Flex Flexible”; approved equal.
10. Roof Ventilation at Ridge
Continuous ridge vent.

Acceptable manufacturers: Cor-A-Vent; GAF Cobra; or approved equal.

11. Provide continuous gutters and downspouts, with prefinished aluminum and 1/8" per foot slope minimum. Fasten according to manufacturer's recommendation. Provide splash guards at all down spouts. Provide product data and samples for Owner or Architect approval.

Gutters not required at detached garages. Refer to division 11 for information on required rain barrels.

12. Flashing at front porch - EPDM flashing

At structures with basements: Between WRB at box sill and porch/stoop concrete deck provide 24" wide 60mil EPDM flashing under .027 alum. flashing coil stock. Extend flashing min. 6" above top of deck. Flashing provided by CC.

13. Gaskets

1/4" x 3.5" or 4" closed cell polyethylene gasket between top of fndn and mudsill;

14. Sealant –

- Continuous draftstop bead between the subfloor and the bottom exterior wall plate;
- Set all ext. door thresholds in continuous bead of sealant. One 10oz tube per door.
- Set all windows sills in continuous bead of sealant. Alternately, windows may be shimmed up to allow for low expansion foam below sill by insulation contractor. Verify window RO. Coordinate with WRB installation specifications;
- Where noted elsewhere in specifications;
- Wallboard gap around bath fans installed into ceilings shared with attic;
- At attic scuttle per mnfr spec;
- At mechanical penetrations between unconditioned spaces and conditioned spaces or wall cavities. (basement is considered a conditioned space)

Acceptable sealant manufactures: Dow Corning 795; Tremco Spectrum 2; approved equal.

15. Sealant/caulk – other locations

- Sealant at tub/flooring edge and stool perimeter noted under division 15.
- Exposed caulk/sealants at painted trim per division 9.

Caulk used at interior and exterior exposed painted surfaces may be acrylic latex. Paintable. Acceptable mnfr: DAP alex plus acrylic latex caulk plus silicone 35 year; approved equal

16. Fire resistant caulking to be 3M Fire Barrier Sealant system or approved equal.

17. Gypsum wallboard adhesive

Continuous bead:

between the bottom plate and the drywall; and
between the top plate and the drywall; and
around window and door RO's.

18. WRB moisture and air barrier system

It is the intention of this specification to provide an integrated vapor permeable and air barrier system. Coordinated products and attention to detail are required to achieve this.

Dupont Tyvek system for house and detached garage:

Apply Tyvek Housewrap per manufacturer specifications and with plastic washer 'cap nails.

Items noted as “optional” in the Dupont publications are not required except as required for air-barrier application. Penetrations through the WRB to be handled as noted under ‘WRB penetrations’ below.

- a. General instructions: DuPont Tyvek Water-Resistive and Air Barriers Installation Guidelines for main house, Dupont publication K16282.
Tyvek at detached garage is not required to be installed as an air barrier.
- b. Integral flanged window: Installation Instructions for Integral Flanged Window AFTER Water-Resistive Barrier (WRB) is Installed, Dupont publication K16795.
- c. Non-flanged entry doors: (specified 5/4 casing trim applied after install) Installation Instructions for Non-Flanged Door AFTER Water-Resistive Barrier (WRB) is installed, Dupont publication K25734. This method is for all exterior doors between conditioned and unconditioned spaces. Service doors to garages from exterior are not included.

- d. WRB Penetrations for base bid
Penetrations through the WRB shall be sealed as follows:

Electrical wire penetrations for single fixture or device at exterior wall – Dupont StraightFlash per Dupont specification for penetrations. No Quickflash panel required.

4” dryer vent penetration – QuickFlash P-300 flashing panel. Dryer vent closure (by MC) mounted on 5/4 trim block. Joints sealed with Dupont Straightflash.

Range vent hood penetration - Dupont StraightFlash at Broan flanged wall cap. Joints sealed with Dupont Straightflash.

HVAC line-set penetration – QuickFlash A/C U-S “universal squared” lineset flashing panel. Joints sealed with Dupont Straightflash.

Hose bibs – QuickFlash P-50 plumbing flashing panel & Dupont Straightflash.

HVAC vent penetrations (both) – QuickFlash P-200 flashing panel & Dupont Straightflash.

Direct vent water heater – QuickFlash P-200 flashing panel & Dupont Straightflash.

Electrical service penetration – QuickFlash P-150 for 1.5” PVC service conduit & Dupont Straightflash.

Telephone and cable penetrations – one each – Dupont StraightFlash per Dupont specification for penetrations. No Quickflash panel required.

PVC conduit to detached garage (not req’d at garage end) – QuickFlash P-150 & Dupont Straightflash.

MEP contractors to verify all conduit and penetration sizes to match w/ Quickflash size. For add’l information on Quickflash panels refer to:
www.quickflashproducts.com/install_plumbing_post.html

WRB Mock up

Before any windows or exterior doors are installed, Contractor to provide a single mock-up of each the following for inspection and written approval by SBH and the Dupont Tyvek representative:

- a. WRB system at typical first floor window (nail fin)
- b. WRB system at typical rear entry door (no nail fin)
- c. WRB system at typical mechanical penetration at rim joist (with QuickFlash panel)
- d. WRB system at Tyvek laps and edges.

Mock up may be in-situ and left in place if approved.

DIVISION 8 – DOORS AND WINDOWS

1. General: Provide shop drawings, product data and samples for Owner or Architect approval. Refer to door and window schedules for additional information.

2. Interior doors, hardware, and keys:

Craftmaster 1 3/8" Carrara smooth panel interior door. Pre-hung pine jambs, eased edge stop, and satin nickel hinges. Door panel pre-primed. Finish paint in the field. CC to provide interior pocket door frames by framer where occurs.

Hardware: Schlage lever style handle – Accent or Flair; Finish: Satin Nickel; Passage function for all interior doors unless noted otherwise; Bathroom door locksets shall be Privacy function with standard emergency unlock feature; Closet doors to match; install door bumpers/stops throughout.

Coordinate undercut at all interior doors with HVAC contractor for adequate return air CFM.

3. Exterior Entry doors, hardware, and keys:

Therma-Tru, Smooth Star S606SDL fiberglass; Per schedule; Swing: as noted per Drawings; Finish: painted. No brick-mould trim. Provide exterior casing trim to match windows. Flashing per division 7. .

Garage service door: Therma-Tru, Smooth Star S606SDL fiberglass; Per schedule; Swing: as noted per Drawings; Finish: painted. No brick-mould trim. Provide exterior casing trim to match windows.

Hardware: Front Entry Door - Schlage Front Entry Handleset – F60 Addison; Finish: Satin Nickel. F60ADD619FLAADD

Hardware: Rear Entry and Garage Entry Doors - Schlage security knob and deadbolt; Finish: Satin Nickel. F51A-619 with F series lever and matching deadbolt keyed alike.

Separate deadbolt with thumb turn fnx. Entry sets at front, exterior rear, and detached garage service doors.

Keys: provide owner with minimum 2 sets of keys for each house. Keys for each individual house and garage to match.

Temporary entry doors: Install temporary door panel into installed frames at front and rear entry door locations. Provide keyed construction lock. Provide SBH with keys for distribution to contractors.

Installation and coordination of permanent doors and locksets/keys is covered in the bid package descriptions.

Temporary entry locksets: During construction install temporary keyed lockset at front and rear doors. Distribute keys to SBH only. Change out to finished locksets after final cleaning.

4. Garage Door: Steel Insulated raised panels (no windows); 1/2 hp door operator; hazard detection; (2) remote operators; and (1) wired push button operator located at garage interior either adjacent to service door (detached garage) or adjacent to door into house (ADA units). Acceptable manufacturers: Overhead Door Co. – Thermacore 297 Series; approved equal. Color t.b.d. from standard colors.
5. Attic access door:
22"x30" Air-tight attic access scuttle door. Minimum R42. No lock option required.
Acceptable manufacturers: Battic Door EZ Hatch 42 or approved equal. Install per mnfr. specifications with sealants per division 7. Interior Trim Carpenter to provide and install.
6. Windows:
Andersen Silverline 3900 Series double hung windows are accepted. Energy Star low-E glazing. White. Tempered where required by code. With screens. Maximum u value = .29.

DIVISION 9 – FINISHES

1. Gypsum Board: 1/2" thick board on all walls, ceilings, and stair ceilings leading to the second floor; 1/2" thick water resistant board on all walls and ceilings at tub/shower locations.
Walls to be finished smooth. Uniform light knockdown texture on ceilings. Rated assemblies as required per drawings/wall schedule.
All wallboard products used on this project must contain a minimum of 50% recycled content. Submittals required for wallboard.
2. Paint Systems: Sherwin-Williams® ; approved equal

Interior Paint

Preparation of all surfaces – caulk and nail hole spackle

Walls: one (1) coat primer + two (2) coat Eggshell finish; assume two (1) color different than ceiling color for all walls.

Ceilings: one (1) coat primer + one (1) coat flat finish; Sherwin-Williams ProMar 200.

Window casing, doors, base: (1) coat Semi-Gloss Finish (trim installed primed) and touch up as required; Sherwin-Williams Pro-Classic

Walls: one (1) coat primer + two (2) coats satin finish; Sherwin-Williams Harmony Low VOC..

Windows: prefinished

Stair handrail and wall cap: stain/polyurethane;

Stair treads (at non basement stairs): stain and poly

Stair risers (at non basement stairs) : painted risers to contrast with stain/poly treads.

Basement steps – no finish on treads. Skirts painted.

Note that windows are installed pre-finished white semi-gloss.

Interior colors:

All ceilings to be painted SW6119 “antique white” flat matte

All interior non-bedroom walls to be painted SW6106 “Kilim Beige” eggshell

All bedroom and bedroom closet walls to be SW6108“Latte” eggshell

Half wall caps and handrails stain and poly finish.

Provide color sample submittal for Owner or Architect approval.

Exterior Paint

Preparation of all surfaces, caulk, and prime paint prior to applying finish coat.

Trim: Smooth pre-primed surface - two (2) coat Semi-gloss exterior latex
Composite Columns: To match railing, semi-gloss finish as per manufacturer's requirements.
Provide paint color sample submittal for Owner or Architect approval.
See division 6 for description of aluminum soffit, fascia, porch ceiling, etc.

Exterior face of exterior entry doors (two per house) to be painted one of six accent colors

Accent colors: (refer to Division 6, exterior finish schedule for locations)

Option #1: SW6433 "Fiery Brown" (a dark red/brown)

Option #2: SW6433 "Inverness" (a dark green)

~~Option #3: SW6300 "Burgundy"~~

~~Option #4: SW6629 "Jalapeno" (a terra cotta)~~

~~Option #5: SW6426 "Basque Green" (green similar to the accent shakes)~~

~~Option #6: SW6307 "Fine Wine"~~

Assume that all colors are deep (clear) base colors.

Caulk used at interior and exterior exposed painted surfaces per division 7.

3. Floor finish:

All vinyl flooring must meet Carpet and Rug institute's Green Label certification.

Vinyl sheet goods – glue down full spread. Installed per mnfr. specifications.

Acceptable manufacturers: Armstrong 62A66 "Ventara" Color: Baron; or approved equal.

Underlayment to be 6mm 5-ply. Popply or approved equal.

Floor preparation & leveling compounds: Ardex K-15 / Feather Finish, or approved equal.

Clear silicone sealant at edge of tub/shower units.

Submittal on vinyl and underlayment required.

Location of vinyl: Vinyl flooring to be at all kitchens, bathrooms, laundry areas, living rooms, and a 3'x3' area inside front and rear door if not otherwise noted as vinyl.

4. Carpet Floor finish:

All carpet/pad must meet Carpet and Rug institute's Green Label certification.

Carpet to be min. 35oz. nylon cut textured pile with min. 3.5 wear rating and integral stain repellent. Color t.b.d.

Install over .5" rebond pad with min. 6lb density.

Acceptable manufactures: Shaw; Armstrong; Mowhawk; or approved equal.

Submittal on carpet and pad required.

Location of carpet: Carpet to be at all bedrooms, hallways outside bedrooms, ~~and living room areas.~~

Transition strips at all vinyl/carpet intersections and nosing at top of basement stairs.

Transition strips to be alum. – color: t.b.d.

5. Floor finish – stairs: refer to interior painting, division 9.

DIVISION 10 – SPECIALTIES

1. House Numbers – metal min. 4" tall. Color: Black. Coordinate location of house numbers with SBH.

2. Mailboxes – USPS approved surface mounted horizontal metal mail box. Color: Black. Minimum size: 15” wide x 6” tall x 3” deep. Locate at front porch. Mount +48 above porch floor. ~~-(+42” at ADA units.)~~

DIVISION 11 – EQUIPMENT

- ~~1. Appliances: SBH to provide the following appliances:~~

No range, dishwasher, or refrigerator installed or provided in this scope of work.

DIVISION 15 – HVAC

1. Contractor shall furnish and install complete and efficient residential HVAC system. All work shall be in accordance with all applicable codes and is subject to City and NIPSCO inspection(s). Make all final connections to City water and sewer systems and NIPSCO gas.
2. System design: HVAC contractor to provide written heating and cooling calculations to verify equipment and ductwork sizes. Manual J. Provide these calculations after contract award and before start of work. Coordinate any required adjustments or changes with SBH.
3. HVAC equipment: Acceptable HVAC equipment manufacturers are: Coleman; Carrier; Rheem; Lennox; ~~Goodman~~; Armstrong.
Gas furnaces shall be minimum 95% efficient.
Provide filter slot with sliding closure panel. Filter to be standard 1” type and sized for airflow. Provide filter. AC unit shall meet Energy Star product criteria. \geq SEER 14.
4. Ductwork supply and return to each major room and bedroom. All ductwork joints, seams, collars, cleats, and connections to be sealed with specified mastic or UL181 rated tape. Framed bays that served as RA chases to be checked and sealed/caulked prior to wallboard installation, especially at cavity tops and where they connect through floor assemblies. Except for bathroom ventilation, no ducts are to be located in unconditioned spaces or attic. No flex or semi-rigid duct is permitted unless otherwise noted.

Thermo-Pan duct panning board is permitted at basement ceilings for return air chases. Panning installed per manufactures specifications to minimize duct cavity leakage. Coordinate pan installation with any box sill foam insulation.
5. Provide gas supply piping to all listed gas appliances. Shut offs, drip legs, and other as required. Coordinate gas line pressure test with city of South Bend inspector at same time as rough-in inspection. Pipeflex is approved.
Installation, testing, and inspection of the gas piping from the gas meter location to the furnace are to occur during rough-in. All exterior mechanical penetrations through the WRB per division 7.
6. Cutting, notching, and drilling or structural members per the IRC.
7. MC to provide and install all dryer vent ducts, exterior wall vent caps, recessed wall boxes behind dryers. Seal all venting ductwork joints and connections with alum. tape or fluid applied mastic duct sealant. Recessed clothes dryer box may be plastic type. No flex or semi-rigid duct is permitted unless otherwise noted.

8. Exterior dryer vent closure mounted on 5/4 wood trim block sized for vent. Acceptable dryer vent caps are: Heartland; Lambro Ind. 289W; approved equal.
9. Thermostat:
Hardwired. Programmable. Honeywell RTH7500D or approved equal.
- ~~10. The following appliances are provided by SBH, uncrated, and set in place by appliance contractor, leveled and hooked up and tested by MC:
Gas range, including anti-tip device~~
11. The following appliances provided by MC, uncrated and installed by MC, controls and wiring by EC:
 - Range hood – vented to exterior at kitchen range. Broan QML30WW. 3.25" x 10" ducted to exterior via wall cabinet above unit. Provide Broan 639 wall cap.
Duct sealing and sealant at WRB per Division 7.
 - Main bathroom exhaust fan: Central bathroom exhaust fan to be Broan Ultra ZB80L. 4" rigid ducted. Sealed duct joints. Wired for continuous operation to meet ASHRAE Standard 62.2. Light, night light, and fan operation switched separately.
For sidewall, vent fan wall cap to be Broan 885BL.
For soffit, vent fan wall cap to be Lambro 143W; Duraflo; or approved equal. White. Flex aluminum duct allowed for connection of cap to rigid duct penetration at WRB only.
Duct sealing and sealant at WRB per Division 7.
Electric control device provided by EC.
 - Second bathroom exhaust fan: For houses with more than one bathroom that is not a half bath, additional exhaust fan to be NuTone 769RFT. 4" rigid ducted. Sealed duct joints. Fan and light switched separately. No continuous operation required.
For sidewall, vent fan wall cap to be Broan 885BL.
For soffit, vent fan wall cap to be Lambro 143W; Duraflo; or approved equal. White. Flex aluminum duct allowed for connection of cap to rigid duct penetration at WRB only.
Duct sealing and sealant at WRB per Division 7.
Electric control switch provided by EC.
 - Half bath exhaust fan: For each half bath, provide and install NuTone #763 w/ 4" rigid ducted. Sealed duct joints. Fan and light switched separately. No continuous operation required.
For sidewall, vent fan wall cap to be Broan 885BL.
For soffit, vent fan wall cap to be Lambro 143W; Duraflo; or approved equal. White. Flex aluminum duct allowed for connection of cap to rigid duct penetration at WRB only.
Duct sealing and sealant at WRB per Division 7.
Electric control switch provided by EC.

DIVISION 15 - PLUMBING

1. Contractor shall furnish and install complete and efficient residential plumbing system. All work shall be in accordance with all applicable codes and is subject to City inspection(s). Make all final connections to City water and sewer systems.
2. Provide 5/8" water meter 'ram's horn' base and fittings as required for City of South Bend 5/8" water meter. Installation of a ball valve shut off at the 1" copper water supply line is to occur

during plumbing rough in. Ram's horn may be installed at trim out, however we prefer that it is also installed at rough in. Refer to Division 2 (site contractor) for information on water supply line from city main.

3. Sewer lateral to basement interior by site contractor to a location under footing. PC to coordinate all below slab plumbing, floor drains, and sump baskets with site and foundation contractor(s) as required.
4. Provide and install PEX water supply lines to all plumbing fixtures, water heater and appliances. No PEX joints permitted inside wall cavities except at necessary branch fittings to fixture termination devices. Either color code (a) all cold as blue and hot as red or (b) all white.
Distribution system to be branch layout.
Install PEX per mnfr. specifications with appropriate supports, clips, and required accessories.
Recessed laundry box at all washer/dryer locations.
~~PEX layout to include cold/hot manifolds and home-run lines to each fixture.~~
5. All exterior mechanical penetrations through the WRB per division 7.
- ~~6. Provide gas piping to furnace, range, water heater, and clothes dryer. Shut off/valve at each termination. Coordinate exterior termination location with SBH and NIPSCO. Mechanical penetrations through the WRB per division 7.~~
7. Provide braided SS connections at stool, lav., and kit sink. Locate stool connection 3" above top of baseboard trim for stools located against interior walls. Quarter turn shut off valve at each plumbing fixture connection. Dishwasher connection in kitchen sinkbase cabinet to be dual valve such that dishwasher can be isolated from the kitchen faucet.
8. Provide and install two (2) exterior hose-bib faucets, freeze proof. Plumb separate from future soft water system loop. Ideally, the hose bib toward the rear of each house is near the proposed rain barrel location.
9. Provide and install (1) PVC basement level floor drain tied to sewer lateral. Assume that sewer lateral is below basement slab.
10. Provide and install footer sump pump and piping to exterior of building. Provide Quickflash panel for drain pipe as required.
11. Cutting, notching, and drilling of structural members per the IRC.
12. Fire caulk to be 3M Fire Barrier Sealant system or approved equal.
13. Sealants – clear silicone sealant at base of stool.
14. PC to protect tubs during const. w/ cardboard or equivalent tub liner.
15. Water heater
Provide and install 40 gallon, quick-recovery power-vent gas water heater. Acceptable water heater manufacturers are State; Rheem; A.O. Smith.
Energy factor to be ≥ 0.67 . 6 year limited tank warranty. Energy Star rating required.
Water heater insulation blanket is not required. Water heater installation must have heat traps in the piping connection design.

16. Garbage disposal
Provide and install garbage disposal. Switched at wall per division 16. Product noted below.
17. Refer to Drawings for Site Plan, Floor Plans, Elevations (for exterior wall openings), and Mechanical/Electrical Systems Reference Plan.

18. PLUMBING FIXTURES

Provide shop drawings and product data for Owner or Architect approval. Verify left/right handed for each location per plans and site plan. (that is, check for mirrored plans)

BATHROOMS:

- Toilet: Delta Corrente C43904-WH (HET). Max. 1.28 gpf. With coordinated seat/lid, wax ring; Color: white Clear silicone at base.
- Lavatory Faucets: Delta Foundations B2515LF-PPU (1.5 gpm)
- Lavatory Bowl: 19x19 porcelain self-rimming drop-in sink with 4" centerset. Color: white.
- Shower Faucet: Delta Foundations BT13010 valve trim (where applicable) plus Delta 7-spray hand held shower 75701 (2.0 gpm)
Handheld shower faucet is for all shower units and ADA Xfer showers.
- Tub/Shwr Faucet: Delta Foundations B114900 (fixed head shower is 2.0 gpm)
- Tub/Shower: 60" fiberglass tub/Shower unit. Color: white.
Acceptable mnfr: Sterling Ensemble 71124106; Aker ; approved equal.
- Shower 36x36 fiberglass shower unit. Verify L/R. Color: white.
Acceptable mnfr: Sterling; Aker ; approved equal. Verify L/R. Color: white.
- ADA Xfer shower fiberglass. color: white
Acceptable mnfr: Sterling 62050125-0; Aker OPS-3636 141274-R/L; approved equal. Verify left/right compliance per ADA.
- Ped sink at ½ baths ProFlo PF1045WH (leg) & PF5004WH (bowl)

KITCHEN :

- SS Kit Sink: Sterling Middleton 20-Gauge Double-Basin Drop-In model #R14708-4-NA (coord. 3 or 4 holes w/ faucet soap dispenser)
- Kitchen Faucet: Delta B4310LF-SD. Chrome. ADA compliant. 1.8 gpm (Verify that faucet comes with accessory soap dispenser before ordering sink)
- Garbage Disposal: Insinkerator Badger 1. Switch at wall.

DIVISION 16 - ELECTRICAL

1. Contractor shall furnish and install complete 200 amp electrical service.
40 slot main breaker panel surface mounted on fire resistant plywood panel per division 6.
Acceptable manufactures: Square D; Siemens ITE;
Clearly print description of each circuit at breaker box.
All work shall be in accordance with all applicable codes and is subject to City of South Bend and AEP inspection(s).
Electrical service to the house is to be underground.

2. Meter bases to be installed on trim block provided by siding contractor. Do not install meter base directly to sheathing or WRB. Coordination is required per division 7.
3. Temporary power
Where noted on schedule, provide 4x4 post, plywood panel, meter base, breaker box, and (2) quad exterior GFIC receptacles. Overhead service cable coordinated with SBH and AEP.
4. Coordinate cat-5 and cable services, installation, routing and connections with SBH. Coordinate with utility providers for underground drops. Provide cable connection in each bedroom and living room. Route each cable to location on plywood adjacent to electrical panel. Leave looped at panel without termination.
No daisy-chain configuration – each cable and coaxial wire is separate. Terminate each cable at wall plate.
5. All exterior mechanical penetrations through the WRB per division 7.
6. Devices
All lighting devices and lamps provided by SBH unless otherwise noted. Delivered to site by SBH in groups of 3 houses.
Door bell, utility 'key-less' fixtures, all non-lighting devices, and electrical devices not otherwise assigned to others in this RFP are to be provided by EC.
7. All devices per code. Color of all devices and cover plates to be light almond.
8. Combination smoke and CO detectors per code. Hardwired with battery backup per code. Hush feature. Acceptable manufactures: Kidde; First Alert.
9. Provide one ceiling fan j-box per house. Separate control for light/fan. Location to be finalized in the field. Rotary fan control provided by EC. Fan/light fixture provided by SBH.
10. Refer to Drawings for Floor Plans, Elevations, and Mechanical/Electrical Systems Reference Plan.
11. Doorbell - hardwired chime and button. Button at front door. Exterior doorbell button must be self-lit.
12. (1) 20A GFIC protected circuit to detached garages via buried wire. Wire in conduit from grade into each structure per code. Draft seal conduit penetration at house WRB per division 7. Sealant putty at both conduit ends.
13. At basements, provide basement level power and/or receptacles as required for water heater, furnace condensate pump, sump pump; footer drain sump, and future water softener system. (3) key-less switched fixtures in each basement switched to top of basement stair. (2) keyless switched fixtures per garage.
14. Light switches to be located 48" above the finished floor as measured to top of rough in box.
15. Motion light. Install one SBH provided switched motion light at garage and one at rear of main house.
16. Provide (1) 220v dryer receptacle at laundry location at each house. Breaker as required. (gas also provided)

17. Provide (1) 220v range receptacle at kitchen range location. Breaker as required. Provide 110v range receptacle at same location. (gas also provided)
18. Exhaust fans and fan/lights
Wire main bathroom fan for continuous operation by switching the red (high speed) leg and leaving black wire (low speed) hot. At all other bathroom, all fan features wired for switch function.
Range hood power – receptacle in cabinet over range hood.
(HVAC contractor to provide fan units, ductwork, caps, and any penetrations for exhaust fan ducts at exterior)
EC to provide exhaust fan controller at each MC provided fan location.
Broan 62V (ivory) at main (common full bath) location. (2 switched plus dial)
Broan 57V (ivory) & separate light switch at all additional bathrooms.
19. Coordinate power to mechanical and plumbing systems provided by MC and PC:
Garbage disposal switched at wall.
Gas water heater.
Ventilation systems listed above.
20. The following appliances are provided by SBH, uncrated and set in place by appliance contractor, and hooked up and tested by EC:
None.
- ~~21. The following appliances are provided by SBH, uncrated and set by appliance contractor, installed by PC, and wired by EC:
Dishwasher. Whip will be provided by appliance vendor. To recep in sink base cabinet.~~

421 Sherman Bid Form – For Package: (fill in one bid package letter per bid form)

Issued date: Monday, March 14, 2022

Due date: Wednesday, April 6, 2022

Having thoroughly examined both the Contract Documents and the site conditions, I hereby propose to furnish all labor and material to accomplish the indicated Bid Package for the following prices:

- **Base bid:** I agree to perform the Work of Bid Package for the lump sum of:
_____ (\$ _____)
- My full and complete markup on any positive value change orders will be _____ %

Alternate work: For the work described below and elsewhere in the Contract Documents, you may revise the foregoing Base Bid as follows:

For: _____ Add (+) Deduct (-)
.....

	\$ _____
(please attach any voluntary alternates on a separate sheet)	

I acknowledge receipt of the following Addenda: Addendum No: _____ | Addendum No: _____

- Include with this proposal the following: (just one copy if submitting more than one proposal)
- ~~the completed AIA-A305~~
 - the requested references as described under "References" above
 - voluntary alternates if any

Signed: _____ Title: _____ Date: _____

Company: _____

SOUTH BEND HERITAGE FOUNDATION

803 LINCOLNWAY WEST SOUTH BEND, IN 46616

PHONE (574)289-1066 FAX (574)289-4550

South Bend Heritage Foundation

803 Lincolnway West

South Bend, IN 46616

Requirements for Certificates of Insurance

- **Commercial General Liability Requirements:** \$1,000,000
- **Commercial Auto Policy Requirements:**
Minimum Combined Single Limit per Accident: \$500,000

NOTE: If using a personal vehicle you must carry non-owned/hired auto liability

- **Workers Compensation and Employers Liability***
Minimum Employers Liability Limits: \$100,000/\$500,000/\$100,000
- **Umbrella Liability Requirements:**
Minimum Limits \$1,000,000

Additional insured:

South Bend Heritage Foundation, Inc., its subsidiaries and agents must be listed as an additional insured.

*SBHF will accept a valid Indiana Department of Revenue Workers' Compensation Clearance Certificate for Independent Contractors in lieu of Workmans Comp coverage. Sole proprietors and/or partnerships meeting certain criteria are eligible for apply. Information and applications are available on line at the Dept. of Revenue's website at www.state.in.us/dor.

Bidder References

Issued date: Monday, March 14, 2022
Due date: Wednesday, April 6, 2022

Property: 421 Sherman Avenue
All Bid Packages

Please provide no less than two prior client names and contact information in which your company demonstrated an ability to deliver a project under a demanding schedule or otherwise met your clients schedule expectations.

1		
2		
3		